

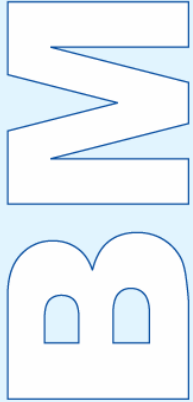

ChargerCore Family

BM-ChargeCore1.0-V1.2



Brief Manual of ChargerCore1.0 Family

Optimized AS-MCU for Li-Ion Battery Charger

V1.2

April 2006

- ◆ CORERIVER Semiconductor reserves the right to make corrections, modifications, enhancements, improvements, and other changes to its products and services at any time.
- ◆ CORERIVER shall give customers at least a three month advance notice of intended discontinuation of a product or a service through its homepage.
- ◆ Customers should obtain the latest relevant information before placing orders and should verify that such information is current and complete.
- ◆ The CORERIVER products listed in this document are intended for usage in general electronics applications. These CORERIVER products are neither intended nor warranted for usage in equipment that requires extraordinarily high quality and/or reliability or a malfunction or failure of which may cause loss of human life or bodily injury.

Contents

1. Features

2. Pin Configurations

3. Pin Descriptions

4. Typical Application Circuit

5. Absolute Maximum Ratings

6. DC Characteristics

7. Package Dimensions

8. TTA Specification

◆ Appendix

A. TTA Specification

B. Update History

1. Features

- ◆ Complete Charger for Li-Ion Batteries
- ◆ Very Low Thermal Dissipation
- ◆ CC (Constant Current) Profile
 - ✓ Charge Current : dependent on Maker
 - ✓ ID
 - 1.5K Ω : 750mA \pm 50mA
 - 4.7K Ω : 750mA \pm 50mA
 - 27K Ω : 450mA \pm 50mA
- ◆ CV (Constant Voltage) Profile
 - ✓ Charge Voltage : 4.2V -0.05V/+0.03V
- ◆ Wake-up
 - ✓ Wake-up Charging when the initial battery voltage is below 2.5V
 - ✓ 30 times repeat (charging during 5sec, standby during 2sec)
 - ✓ Fast Charging at 2.5V above
- ◆ Current Cut-Off
 - ✓ 30 ~ 100mA
- ◆ Recharge
 - ✓ When below 4.07V \pm 0.05V
- ◆ Chargeable Ambient Temperature Range
 - ✓ -5 $^{\circ}$ C \pm 3 $^{\circ}$ C ~ 45 $^{\circ}$ C \pm 3 $^{\circ}$ C
- ◆ Charging Time
 - ✓ Fast Charge : 4 hours
 - ✓ Recharge : 2 hours
- ◆ Over-Voltage Protection
 - ✓ Charge Cut-off when 4.35V \pm 0.05 above
- ◆ Error Mode
 - ✓ When battery voltage is greater than 4.35V
 - ✓ Short or Open in charging
 - ✓ Detecting Abnormal Battery
- ◆ LED Display
 - ✓ Red : in charging or in wake-up mode
 - ✓ Green : charge completion or in recharging
 - ✓ Yellow : Stand-by due to Temperature Emergency
 - ✓ Yellow Flickering : in Error mode
- ◆ E.S.D. protection up to 2,000V
- ◆ Latch-up protection up to \pm 200mA
- ◆ Korea TTA Specification Certification
- ◆ Package : 8-SPDIP and -SOIC

2. Pin Configurations

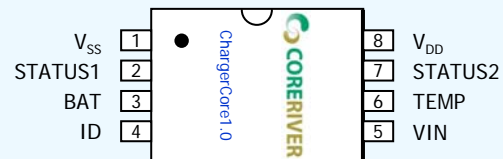

[8-SOIC / 8-SPIDP]

3. Pin Descriptions

Symbol	Direction	Description
V_{DD}	Input	Voltage Power Source
V_{SS}	Input	Voltage Power Ground
BAT	Input	<ul style="list-style-type: none"> ▪ Connected to battery
STATUS1	Output	<ul style="list-style-type: none"> ▪ Bit Programmable with Schmitt Trigger - Optional Pull-up Control Enable - Open-drain Output - Push-pull Output
STATUS2	Output	<ul style="list-style-type: none"> ▪ Bit Programmable with Schmitt Trigger - Optional Pull-up Control Enable - Open-drain Output - Push-pull Output (Default)
TEMP	Input	<ul style="list-style-type: none"> ▪ Input for an external NTC thermistor ▪ used for battery removal detection
VIN	Input	<ul style="list-style-type: none"> ▪ The input power source
ID	Output	<ul style="list-style-type: none"> ▪ Bit Programmable with Schmitt Trigger - Optional Pull-up Control Enable - Open-drain Output - Push-pull Output (Default)

4. Typical Application Circuit

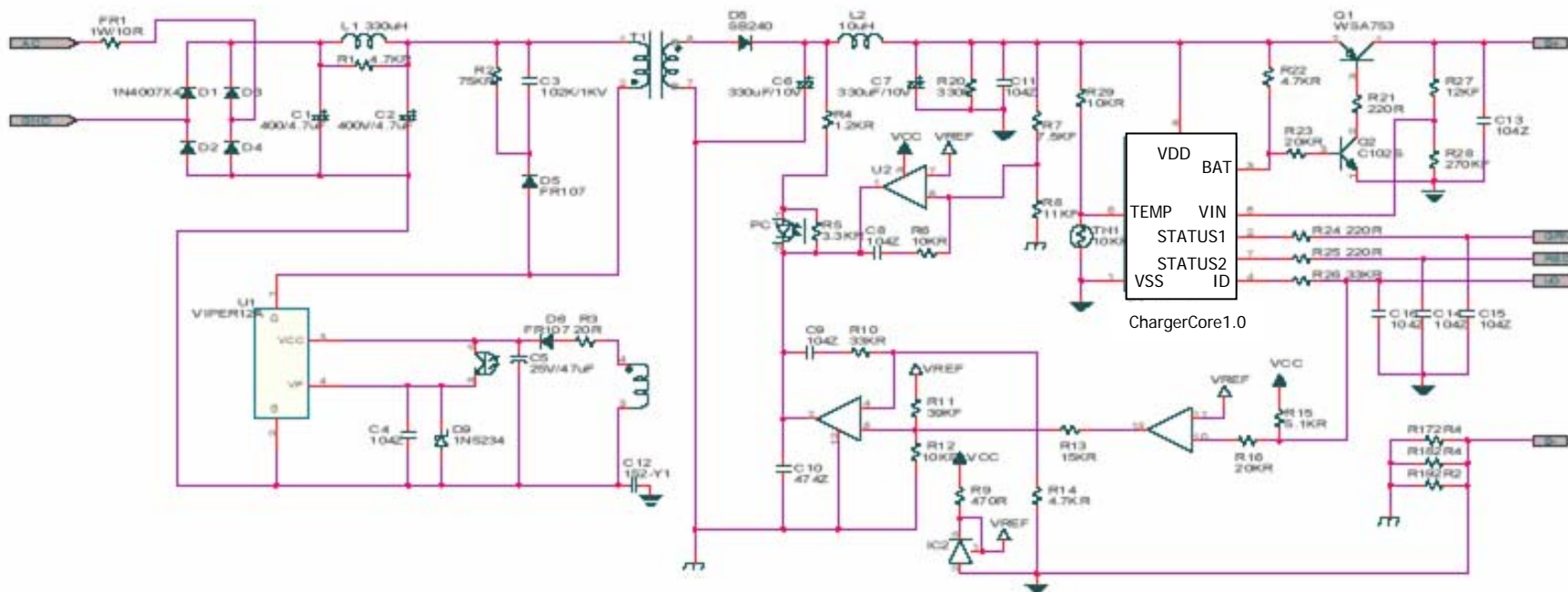

5. Absolute Maximum Ratings

Items	Conditions	Ranges
Voltage on any pin relative to Ground	-	-0.5V to ($V_{DD}+0.5V$)
Voltage in V_{DD} relative to Ground	-	-0.5V to 6.5V
Output Voltage	-	-0.5V to ($V_{DD}+0.5V$)
Output Current High	One I/O pin active	-25mA
	All I/O pin active	-100mA
Output Current Low	One I/O pin active	+30mA
	All I/O pin active	+150mA
Operating Temperature	-	-40 °C to 85 °C
Storage Temperature	-	-65 °C to +150 °C
Soldering Temperature	-	160 °C for 10 seconds

6. DC Characteristics

* TA = -5 °C ~ +45 °C, V_{DD} = 2.4V ~ 5.5V unless otherwise specified.

Parameter	Symbol	Pin	Conditions	Value			Unit
				Min.	Typ.	Max.	
Input Low Voltage	V _{IL1}	STATUS2, TEMP, VIN, ID	V _{DD} = 2.4V~5.5V	-0.5	-	0.2V _{DD} -0.1	V
	V _{IL2}	STATUS1, BAT		-0.5	-	0.3V _{DD}	
Input high Voltage	V _{IH1}	STATUS2, TEMP, VIN, ID	V _{DD} = 2.4V~5.5V	0.2V _{DD} +1.0	-	V _{DD} +0.5	V
	V _{IH2}	STATUS1, BAT		0.7V _{DD}	-	V _{DD} +0.5	
Output Low Voltage	V _{OL1}	STATUS1, STATUS2, TEMP, VIN, ID	I _{OL} = 20mA @V _{DD} =5V (I _{OL} = 5mA @V _{DD} =2.6V)	-	-	0.3V _{DD}	V
	V _{OL2}	BAT	I _{OL} = 10mA @V _{DD} =5V (I _{OL} = 2.5mA @V _{DD} =2.6V)	-	-	0.3V _{DD}	
Output High Voltage	V _{OH}	STATUS1, STATUS2, TEMP, VIN, ID	I _{OH} = -15mA @V _{DD} =5V (I _{OH} = -2.5mA @V _{DD} =2.6V)	0.7V _{DD}	-	-	V
	V _{OHP1}	STATUS2, TEMP, VIN, ID (pull-up resistor only)	I _{OH} = -140uA @V _{DD} =5V (I _{OH} = -20uA @V _{DD} =2.6V)	0.7V _{DD}	-	-	V
	V _{OHP2}	STATUS1 (pull-up resistor only)	I _{OH} = -10uA @V _{DD} =5V (I _{OH} = -1.5uA @V _{DD} =2.6V)	0.7V _{DD}	-	-	V
Input Leakage Current	I _{IL}	All pins except STATUS1	V _{IN} = V _{IH} or V _{IL}	-	-	±1	μA
Pin Capacitance	C _{IO}	All	V _{DD} = 5V	-	10	-	pF

7. Package Dimensions : 8-SPDIP/8-SOIC

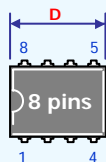

[8-SPDIP]

Symbol	Dimension in Inches			Dimension in mm		
	Min.	Nom.	Max.	Min.	Nom.	Max.
D	0.445	0.455	0.475	11.303	11.557	12.065

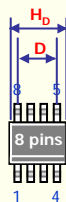

[8-SOIC]

Symbol	Dimension in Inches			Dimension in mm		
	Min.	Nom.	Max.	Min.	Nom.	Max.
D	-	0.150	-	-	3.81	-
H _b	0.189	0.193	0.197	4.80	4.90	5.00

Appendix A : TTA Specification (1 of 3)

Test items		Test condition	Test description	SPEC
Category	Details			
Basic Function	Charging voltage	Room temperature, Load : Cut off current	4.15 ~ 4.23V _{DC}	4.23V _{DC} (set1 : set-up voltage)
	LED display / RED	Room temperature	RED ON	Charging is maintained.
	LED display/GREEN	Room temperature	GREEN ON	Completion of charging
	Overcharge detection	Room temperature	Charging is stopped.	4.3V _{DC} + 0.1V
	Abnormality detection	Room temperature	Charging is stopped.	Load open, Output Short
	Load Regulation	Room temperature, Load : Cut off current ~ 700mA, AC 220V	Measure with change of current (Load)	4.2V _{DC} (Set1 ± 0.05V)
	Line Regulation	Room temperature, AC 85 ~ 264V	Measure with change of AC voltage	4.2V _{DC} (Set1 ± 0.05V)
	Over-current detection	Room temperature, charging voltage 2.5V	The current when voltage drops below 2.5V by increasing load current	450mA ± 50mA (27kΩ) 750mA ± 50mA (4.7kΩ) 900mA ± 50mA (1.5kΩ)
	Output Ripple & Noise	<ul style="list-style-type: none"> Room temperature, AC 85 ~ 264V Load : Cut Off current ~ 700mA Connect 47uF ceramic capacitor at the output port in parallel, bandwidth 20MHz 	Measure with change of current (Load)	Max. 60mV _{pp}
	Reverse Current	Room temperature, output 4.2V, AC power OFF	Measure current flowing from a charger to a phone	Max. 0.5mA
	Compensation charging start voltage	Room temperature, AC 220V	LED display remains GREEN.	4.07V ± 0.05V
	Charging Cut Off Current	Room temperature, AC 220V	<ul style="list-style-type: none"> Set P/S to 4.15V. Then measure with change of current. LED display converts from RED to GREEN. 	Charging is completed at 30 ~ 100mA.
	AC Power ON / OFF	Room temp., 5 sec ON/OFF 30,000 cycles (AC 85V / 264V 15,000 cycles)	Normal operation	Normal operation

Appendix A : TTA Specification (2 of 3)

Test Items		Test condition	Test description	SPEC
Category	Details			
Environ- Mental stress test	Low temp. storage test	Leave it at room temp. for 2 hours.	Normal operation	Normal operation
		-40°C / 48 hours (65% increase in RH) (Power OFF)	No abnormality on the exterior	No abnormality on the exterior
	High temp. storage test	Leave it at room temp. for 2 hours.	Normal operation	Normal operation
		+75°C / 48 hours (65% increase in RH) (Power OFF)	No abnormality on the exterior	No abnormality on the exterior
	Temp. stress test	-40°C/+85°C / 2 hours respectively/15 Cycles	Normal operation	Normal operation
		Rise/drop period: shorter than 5 minutes. Leave it at room temp. for 3 hours.(Power OFF)	No abnormality on the exterior	No abnormality on the exterior
	High temp. high RH operation test	-40°C, 95% RH / 48 hours Max. Load AC 85 ~ 264V	Charging voltage: pass basic function test	4.2V _{DC} ± 0.05V
			Cut off charging at +40°C ± 3°C	Cut off charging
Low temp. operation test	0°C, 95% RH / 48 hours Max. Load AC 85 ~ 264V	Charging voltage: pass basic function test	4.2V _{DC} ± 0.05V	
		Cut off charging at -5°C ± 3°C	Cut off charging	
Electrical Characteristics (Basic stability)	ESD test	KN61000-4-2	No abnormal operation, no component destruction, no deterioration	KN61000-4-2
	Overvoltage applied	AC 300V 1 minute	Normal operation	Normal operation
	Thunderbolt surge	•Ring Wave : ±6kV, 500A / 30 sec period 5 cycles or •Combination Wave : ±2kV, 1kA/30 sec period 5 cycles	Normal operation	Normal operation
	Resisting voltage of insulation	Between the primary and the secondary ports, 3kV application/not exceeding 5mA. 220V:3kV- satisfaction of insulation resistance at the same time	Normal operation	Normal operation

Appendix A : TTA Specification (3 of 3)

Test items		Test condition	Test description	SPEC
Category	Details			
Safety test	Rise of surface temperature	AC : application of rated voltage + 10% Room temperature	Charging continues.	Not exceeding 55°C (ambient temperature 25°C)
	Power dissipation test	Charger power on	HS Power Off + Batt. condition After complete charging, measure with HS attached.	Not exceeding 1W
	AC Leakage Current	Room temperature	Input GND – Output GND, B+	Max. 0.10mA
	Heat generation of components	Room temp., Large capacity Battery charging (Charging current 750mA)	Measure heat at Switching IC, Transformer, Secondary Diode, and Output Tr.	Max. 85°C (Ambient temperature 25°C)
System strength test	Drop test	<ul style="list-style-type: none"> •Height : 120cm •Drop / Twice for each side 	Bare product condition	No abnormal operation, no component destruction, no deterioration

- ❖ RH : Humidity
- ❖ HS : Cellular phone
- ❖ H : Hour
- ❖ Cycle : Repeat
- ❖ ESD : Electric Static Discharge
- ❖ P/S : Power Supply

Appendix B : Update History

- ◆ V1.0
 - ✓ First release
- ◆ V1.1
 - ✓ Specification Update
 - ✓ Add on TTA Specification
- ◆ V1.2
 - ✓ Update TTA Specification