



---

***RTouchCore1.0 Family***  
***Resistive Touch Screen Controller***

---

***Ver. 1.0***

***May 2009***

***Copyright CORERIVER Semiconductor Co., Ltd. 2009***  
***All Rights Reserved***

- ◆ *CORERIVER Semiconductor reserves the right to make corrections, modifications, enhancements, improvements, and other changes to its products and services at any time.*
- ◆ *To discontinue any product or service, CORERIVER should inform customers of that before 3 months through its homepage.*
- ◆ *Customers should obtain the latest relevant information before placing orders and should verify that such information is current and complete.*
- ◆ *The CORERIVER Semiconductor products listed in this document are intended for usage in general electronics applications. These CORERIVER Semiconductor products are neither intended nor warranted for usage in equipment that requires extraordinarily high quality and/or reliability or a malfunction or failure of which may cause loss of human life or bodily injury*

## Table of Contents

<b>1. PRODUCT OVERVIEWS .....</b>	<b>5</b>
1.1 FEATURES .....	7
<b>2. ELECTRICAL CHARACTERISTICS .....</b>	<b>8</b>
2.1 ABSOLUTE MAXIMUM RATING .....	8
2.2 DC CHARACTERISTICS .....	9
2.3 ADC SPECIFICATIONS .....	10
<b>3. PIN INFORMATION.....</b>	<b>11</b>
3.1 PIN CONFIGURATION.....	11
3.2 PIN ASSIGNMENT .....	12
<b>4. TOUCH SCREEN OPERATION .....</b>	<b>13</b>
4.1 4-WIRE TOUCH SCREEN COORDINATE PAIR MEASUREMENT .....	13
<b>5. I<sup>2</sup>C INTERFACE .....</b>	<b>16</b>
5.1 OVERVIEW .....	16
5.2 FEATURES.....	17
5.3 I <sup>2</sup> C INTERFACE OPERTAION .....	18
5.4 MODE OF OPERATION.....	18
5.5 I <sup>2</sup> C PROTOCOL.....	18
<b>5. PACKAGE DIMENSION .....</b>	<b>21</b>
5.1 TSSOP 16 PACKAGE .....	21
5.2 MLF 20 PACKAGE .....	22



## 1. Product Overviews

The low-power programmable touch screen controller, RTouchCore1.0 is designed to work with power-sensitive portable applications.

It contains a complete, programmable, 10 or 12-bit, analog-to-digital (A/D) resistive touch screen converter, including drivers and the control logic to measure touch pressure.

In addition, the RTouchCore1.0 contains a built-in touch engine to preprocess the touch screen measurements. This preprocessing reduces bus loading and the consumption of host processor resources. The reduced resources can then be redirected to more critical function.

The RTouchCore1.0 supports an I<sup>2</sup>C serial bus and data transmission protocol. It offers the 10-bit resolution.

The RTouchCore1.0 is available in a 20-pin MLF package and a 16-pin TSSOP package. It is characterized for the -40°C to +85°C industrial temperature Range.



## 1.1 Features

- Resistive Touch Screen Controller
- 4 or 5 -Wire Touch Screen Interface
- Auto Power-Down Control
- 10 or 12-bit ADC
  - Auxiliary ADC channel input
  - Programmable 10 or 12-bit ADC
- Operating Voltage : 1.8 ~ 5.5V
- Supporting ISP / IAP
- Support User Defined Format
  - Coordinates / Gesture, etc.
- Host Interface
  - 1-channel I2C
  - 1-channel UART
- Package
  - 20-MLF / 16-TSSOP
- ESD Protection
  - 6kV HBM
- Power Consumption
  - Active Current: Max. 1mA @+3.0V, 2MHz
  - Stop Current: Max. 1uA@ +3.0V, (All Power OFF)

## 2. Electrical Characteristics

### 2.1 Absolute Maximum Rating

Items	Conditions	Ranges
Voltage on any pin relative to Ground	-	-0.5 V to ( $V_{DD}+0.5V$ )
Voltage in $V_{DD}$ relative to Ground	-	-0.5V to 6.5V
Output Voltage	-	-0.5 V to ( $V_{DD}+0.5V$ )
Output Current High	One I/O pin active	-25mA
	All I/O pin active	-100mA
Output Current Low	One I/O pin active	+30mA
	All I/O pin active	+150mA
Storage Temperature	-	-60 °C to 150 °C
Soldering Temperature	-	260 °C, 20 seconds within 5 °C of actual peak temperature

## 2.2 DC Characteristics

( $T_A = -40^\circ\text{C} \sim +85^\circ\text{C}$ ,  $V_{DD} = 2.4\text{V} \sim 5.5\text{V}$  unless otherwise specified)

Parameter	Symbol	Pin	Conditions	Value			Unit
				Min.	Typ	Max.	
Input Low Voltage	$V_{IL}$	PENIRQ_B, SDA, SDC	$V_{DD} = 2.2\text{V} \sim 5.5\text{V}$	-0.5	-	$0.2V_{DD}-0.1$	V
Input High Voltage	$V_{IH}$	PENIRQ_B, SDA, SDC	$V_{DD} = 2.4\text{V} \sim 5.5\text{V}$	$0.2V_{DD}+1.0$	-	$V_{DD}+0.5$	V
Output Low Voltage	$V_{OL}$	PENIRQ_B, SDA, SDC	$I_{OL}=20\text{mA} @V_{DD}=5\text{V}$ ( $I_{OL}=3\text{mA} @V_{DD}=2.2\text{V}$ )	-	-	$0.3V_{DD}$	V
Output High Voltage	$V_{OH}$	PENIRQ_B, SDA, SDC	$I_{OH}=-15\text{mA} @V_{DD}=5\text{V}$ ( $I_{OH}=-2\text{mA} @V_{DD}=2.2\text{V}$ )	$0.7V_{DD}$	-	-	V
	$V_{OH2}$	PENIRQ_B, SDA, SDC (Pull-up)	$I_{OHP}=-40\mu\text{A} @V_{DD}=5\text{V}$ ( $I_{OHP}=-15\mu\text{A} @V_{DD}=2.2\text{V}$ )	$0.7V_{DD}$	-	-	V
Input Leakage Current	$I_{IL}$	All pins	$V_{IN} = V_{IH} \text{ or } V_{IL}$	-	-	$\pm 1$	$\mu\text{A}$
Pin Capacitance	$C_{IO}$	All	$V_{DD} = 5\text{V}$	-	10	-	pF

## 2.3 ADC Specifications

Parameter	Symbol	Conditions	Value			Unit	
			Min.	Typ.	Max.		
Supply Voltage	$V_{DDADC}$	-	1.6	-	5.5	V	
Input Voltage	$V_{INADC}$	-	$V_{SS}$	-	$V_{DD}$	V	
Resolution	$RES_{ADC}$	-	-	10	-	Bit	
Operating Frequency	$F_{ADC}$	$V_{DD} = 4.5V \sim 5.5V$ $V_{DD} = 2.4 \sim 3.3V$	-	-	10 5	MHz	
Conversion Time	$t_{ADC}$	-	-	$96/F_{ADC}$	-	sec	
Overall Accuracy	$OA_{ADC}$	$V_{DD} = 5V, F_{ADC} = 10MHz$ $V_{DD} = 3V, F_{ADC} = 5MHz$	-	$\pm 2$	$\pm 4$	LSB	
Integral Nonlinearity	$INL_{ADC}$	$V_{DD} = 5V, F_{ADC} = 10MHz$ $V_{DD} = 3V, F_{ADC} = 5MHz$	-	$\pm 2$	$\pm 4$	LSB	
Differential Nonlinearity	$DNL_{ADC}$	$V_{DD} = 5V, F_{ADC} = 10MHz$ $V_{DD} = 3V, F_{ADC} = 5MHz$	-	$\pm 0.5$	$\pm 1$	LSB	
Zero Input Error	$ZIE_{ADC}$	$V_{DD} = 5V, F_{ADC} = 10MHz$ $V_{DD} = 3V, F_{ADC} = 5MHz$	-	$\pm 2$	$\pm 4$	LSB	
Full Scale Error	$FSE_{ADC}$	$V_{DD} = 5V, F_{ADC} = 10MHz$ $V_{DD} = 3V, F_{ADC} = 5MHz$	-	$\pm 2$	$\pm 4$	LSB	
Analog Input Capacitance	$C_{INADC}$	-	-	10	15	pF	
ADC Current	Active	$I_{ADC}$	$V_{DD} = 5V, F_{ADC} = 10MHz$	-	1	2	mA
			$V_{DD} = 3V, F_{ADC} = 5MHz$	-	0.3	0.6	mA
	Power-down	$V_{DD} = 5V$	-	-	100	nA	

### 3. Pin Information

#### 3.1 Pin Configuration

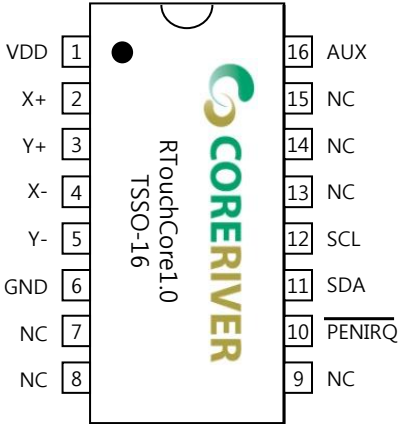
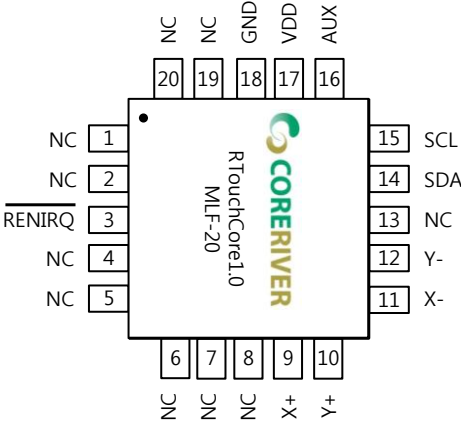

### 3.2 Pin Assignment

Pin No.		Pin Name	I/O	A/D	Description
TSSOP	MLF				
1	17	VDD			Supply Voltage
2	9	X+	I	A	X+ Channel Input
3	10	Y+	I	A	Y+ Channel Input
4	11	X-	I	A	X- Channel Input
5	12	Y-	I	A	Y- Channel Input
6	18	GND			Ground
7	1	NC			Not Connect
8	4	NC			Not Connect
9	8	NC			Not Connect
10	3	PENIRQ_B	O	D	Data Available Interrupt Output. A Delayed (Process Delay) Pen Touch Detect. Pin Polarity with Active Low.
11	14	SDA	I/O	D	I2C - Serial Data / UART - TXD / MDS_SDA
12	15	SCL	I/O	D	I2C - Serial Clock / UART - RXD / MDS_SCL
13	13	NC			Not Connect
14	5	NC			Not Connect
15	6	NC			Not Connect
16	16	AUX	I	A	Auxiliary Channel Input

## 4. Touch Screen Operation

A resistive touch screen operates by applying a voltage across a resistor network and measuring the change in resistance at a given point on the matrix where the screen is touched by an input (stylus, pen, or finger), the change in the resistance ratio marks the location on the touch screen.

The RTouchCore1.0 supports resistive 4-wire configurations, as shown in Figure 1. The circuit determines location in two coordinate pair dimensions, although a third dimension can be added for measuring pressure.

### 4.1 4-Wire Touch Screen Coordinate Pair Measurement

A 4-wire touch screen is typically constructed as shown in Figure 1. It consists of two transparent resistive layers spacers.

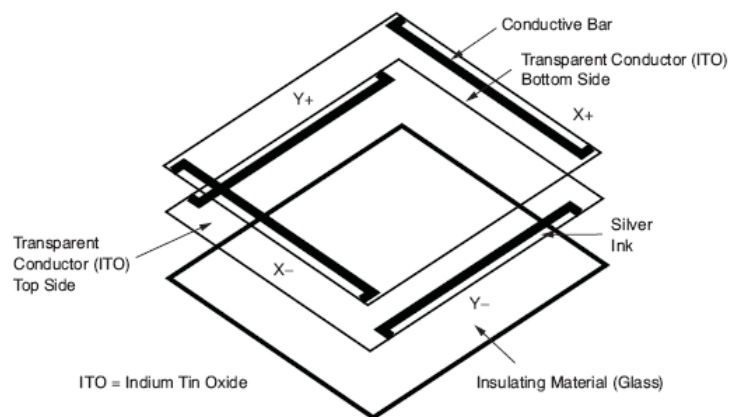

**Figure 1. 4-Wire Touch Configuration**

The 4-wire touch screen panel works by applying a voltage across the vertical or horizontal resistive network. The A/D converter converts the voltage measured at the point where the panel is touched. A measurement of the Y position of the pointing device is made by connecting the X+ input to a data converter chip, turning on the Y+ and Y- drivers, and digitizing the voltage seen at the X+ input. The voltage measured is determined by the voltage divider developed at the point of touch. For this measurement, the horizontal panel resistance in the

X+ lead does not affect the conversion because of the high input impedance of the A/D converter.

Voltage is then applied to the other axis, and the A/D converter converts the voltage representing the X position on the screen. This process provides the X and Y coordinates to the associated processor.

Measuring touch pressure (Z) can also be done with the RTouchCore1.0. To determine pen or finger touch, the pressure of the touch must be determined. Generally, it is not necessary to have very high performance for this test; therefore, 10-bit resolution mode may be sufficient. There are several different ways of performing this measurement. The RTouchCore1.0 supports two methods. The first method requires knowing the X-plate resistance, the measurement of the X-position, and two additional cross panel measurements ( $Z_2$  and  $Z_1$ ) of the touch screen (see Figure 2).

$$R_{\text{TOUCH}} = R_{\text{X-plate}} \circ \frac{X_{\text{Position}}}{4096} \left( \frac{Z_2}{Z_1} - 1 \right)$$

The second method requires knowing both the X-plate and Y-plate resistance, measurement of X-position and Y-position, and  $Z_1$ . Equation 2 also calculates the touch resistance:

$$R_{\text{TOUCH}} = \frac{R_{\text{X-plate}} \circ X_{\text{Position}}}{4096} \left( \frac{4096}{Z_1} - 1 \right) R_{\text{Y-plate}} \circ \left( 1 - \frac{Y_{\text{Position}}}{4096} \right)$$

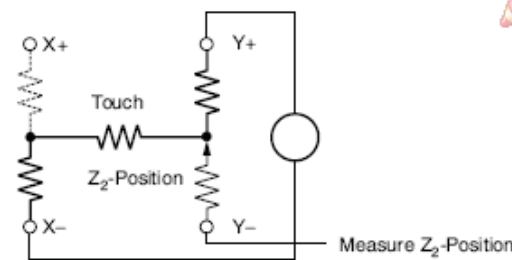
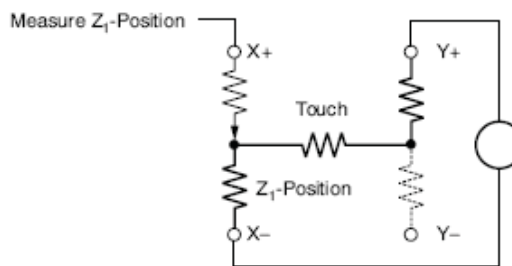
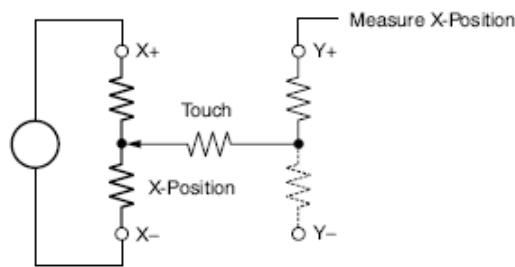

**Figure 2. Pressure Measurement**

When the touch panel is pressed or touched and the drivers to the panel are turned on, the voltage across the touch panel often overshoots and then slowly settles down (decays) to a stable dc value. This effect is a result of mechanical bouncing caused by vibration of the top layer sheet of the touch panel when the panel is pressed. This settling time must be accounted for, or else the converted value is incorrect. Therefore, a delay must be introduced between the time the driver for a particular measurement is turned on, and the time a measurement is made.

In some applications, external capacitors may be required across the touch screen for filtering noise picked up by the touch screen (for example, noise generated by the LCD panel or back-light circuitry). The value of these capacitors provides a low-pass filter to reduce the noise, but creates an additional settling time requirement when the panel is touched. The settling time typically shows up as gain error.

To solve this problem, the RTouchCore1.0 can be commanded to turn on the drivers only, without performing a conversion. Time can then be allowed to perform a conversion before the command is issued.

The RTouchCore1.0 touch1.0 can measure position (X,Y) and pressure (z).

## 5. I<sup>2</sup>C Interface

### 5.1 Overview

The RTouchCore1.0 is an analog interface device for touch screen interface. It has the peripheral functions controlled by the built-in program and the control block. Its features are as follows:

- Low-power touch screen controller
- Very small onboard footprint
- Work on low supply voltage
- Saving host resources by preprocessing for more important tasks
- Minimal connection interface allows the easiest isolation and reduces the number of dedicated I/O pins required
- Miniature, yet complete; requires no external supporting component
- Enhanced electrostatic discharge (ESD) protection

The RTouchCore1.0 consists of the following blocks

- Touch Screen Sensor Interface
- Auxiliary Input (AUX)
- Acquisition Activity Preprocessing
- Internal Conversion Clock
- I<sup>2</sup>C Interface

Communication with the RTouchCore1.0 is done via an I<sup>2</sup>C serial interface. When it operates in the I<sup>2</sup>C slave mode, data are shifted into or out of the RTouchCore1.0 under control of the host microprocessor, which also provides the serial data clock.

Control of RTouchCore1.0 and its functions is accomplished by selecting a built-in program of the internal control block.

A typical application of the RTouchCore1.0 is shown in Figure 3.

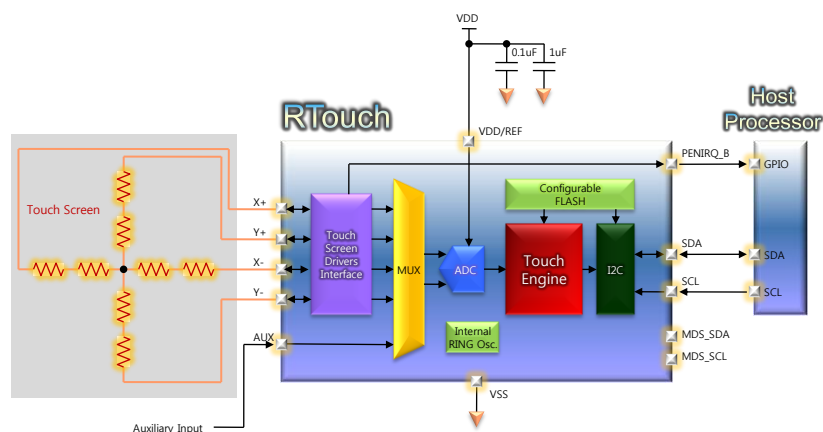

**Figure 3. Typical Configuration**

## 5.2 Features

- Bidirectional data transfer between masters and slaves
- Serial clock synchronization can be used as a handshake mechanism to suspend and resume serial transfer
- The I<sup>2</sup>C bus may be used for test and diagnostic purposes
- Two-wire Interface
- Transmitter or Receiver Operation
- 100Kbps (Min. Fosc = 1MHz), 400Kbps (Min. Fosc = 4MHz)
- 7bits / 10bits (Extended 15bits) Address Mode
- Transfer Wait State
- Fully Programmable Slave Address
- SDA/SCL Schmitt-trigger input
- 256 Programmable Bit Rates
- Wake-up from IDLE mode
- Compatible with Phillips I2C protocol

## 5.3 I<sup>2</sup>C Interface Operation

Data is transferred between a Master and a Slave synchronously to SCL on the SDA line on a byte-by-byte basis. Each data byte is 8 bits long. There is one SCL clock pulse for each data bit with the MSB being transmitted first. An acknowledge bit follows each transferred byte. Each bit is sampled during the high period of SCL; therefore, the SDA line may be changed only during the low period of SCL and must be held stable during the high period of SCL. A transition on the SDA line while SCL is high is interpreted as a command.

## 5.4 Mode of Operation

The on-chip I<sup>2</sup>C logic of the RTouchCore1.0 may operate as a slave and operate in the following two modes:

1. Slave Receiver Mode:

Serial data and the serial clock are received through SDA and SCL. After each byte is received, an acknowledge bit is transmitted. Start and Stop conditions are recognized as the beginning and the end of a serial transfer. Address recognition is performed by hardware after reception of the slave address and direction bit.

2. Slave Transmitter Mode:

After a Start condition or a Restart condition, the first byte is transmitted by the master. The slave then returns an acknowledge bit. Next, a number of data bytes are transmitted by the slave to the master. The master returns an acknowledge bit after all received bytes other than the last byte. At the end of the last received byte, Not ACK is returned. Serial data is transmitted via SDA while the serial clock is input through SCL. Start, Restart, and Stop conditions are recognized as the beginning and the end of a serial transfer.

## 5.5 I<sup>2</sup>C protocol

Normally, a standard I<sup>2</sup>C communication consists of four parts:

- 1) START signal generation
- 2) Slave address transfer

- 3) Data transfer
- 4) WAIT state
- 5) STOP signal generation

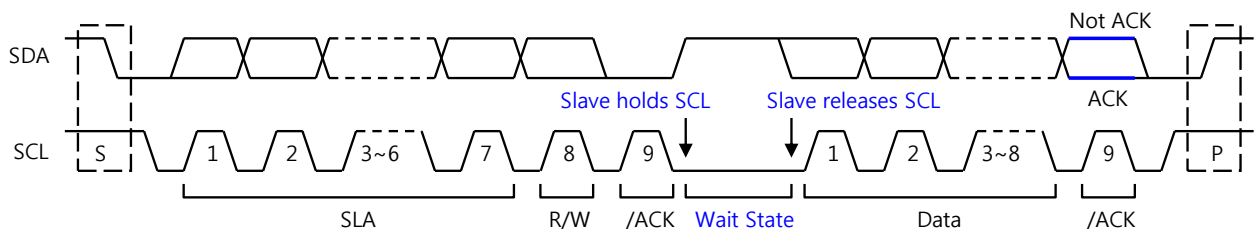

- **START signal** - When the bus is free/idle, meaning no master device is engaging the bus (both SCL and SDA lines are high), a master can initiate a transfer by sending a START signal. A START signal, usually referred to as the START bit, is defined as a high-to-low transition of SDA while SCL is high. The START signal denotes the beginning of a new data transfer. A Repeated START is a START signal without first generating a STOP signal. The master uses this method to communicate with another slave or the same slave in a different transfer direction (e.g. from writing to a device to reading from a device) without releasing the bus.
- **Slave Address Transfer** - The first byte of data transferred by the master immediately after the START signal is the slave address. This is a seven-bit address followed by R/W bit. The R/W bit informs the slave of the data transfer direction. No two slaves in the system can have the same address. Only the slave with an address that matches the one transmitted by the master will respond by returning an acknowledge bit by pulling the SDA low at the 9<sup>th</sup> SCL clock cycle.

Note: The core supports 10 bit slave addresses by generating two address transfers. The core treats a Slave Address Transfer as any other write action. Store the slave device's address in the Transmit Register and set the W/R bit. The core will then transfer the slave address on the bus.

◆ 7-bit Address Format

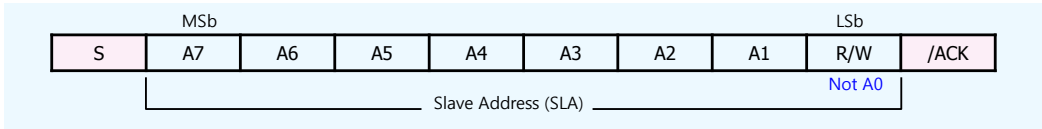

◆ 10-bit / Extended 15-bit Address Format

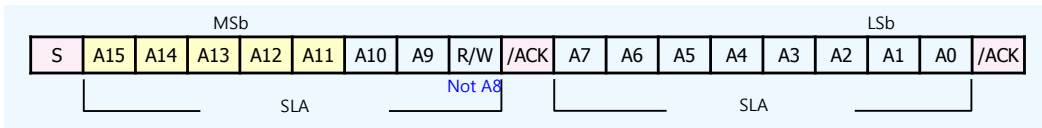

- **Data Transfer** - Once successful slave addressing has been achieved, the data transfer can proceed on a byte-by-byte basis in the direction specified by the R/W bit sent by the master. Each transferred byte is followed by an acknowledge bit on the 9<sup>th</sup> SCL clock cycle. If the slave signals a No Acknowledge, the master can generate a STOP signal to abort the data transfer or generate a Repeated START signal and start a new transfer cycle.

◆ Data Transfer from a Master

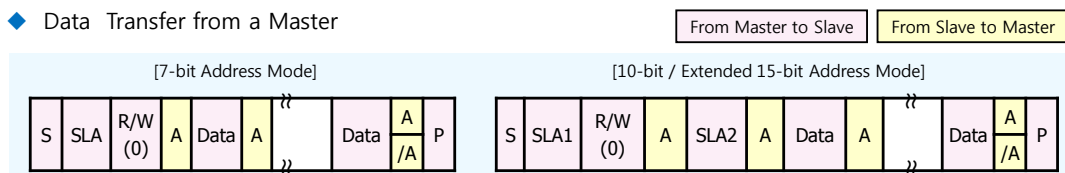

◆ Data Transfer to a Master

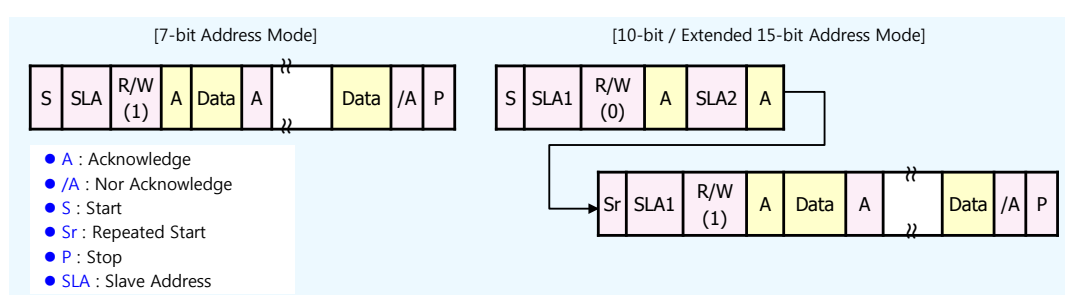

- **WAIT state** - A slave can delay next byte transfer by pulling down the SCL line. Then the master enters the WAIT state. The state is maintained until the slave release the SCL line. After exiting from the state, the master transfers the next byte.
- **STOP signal** - The master can terminate the communication by generating a STOP signal. A STOP signal, usually referred to as the P bit, is defined as a low-to-high transition of SDA while SCL is at logical 1.

# 5. Package Dimension

## 5.1 TSSOP 16 package

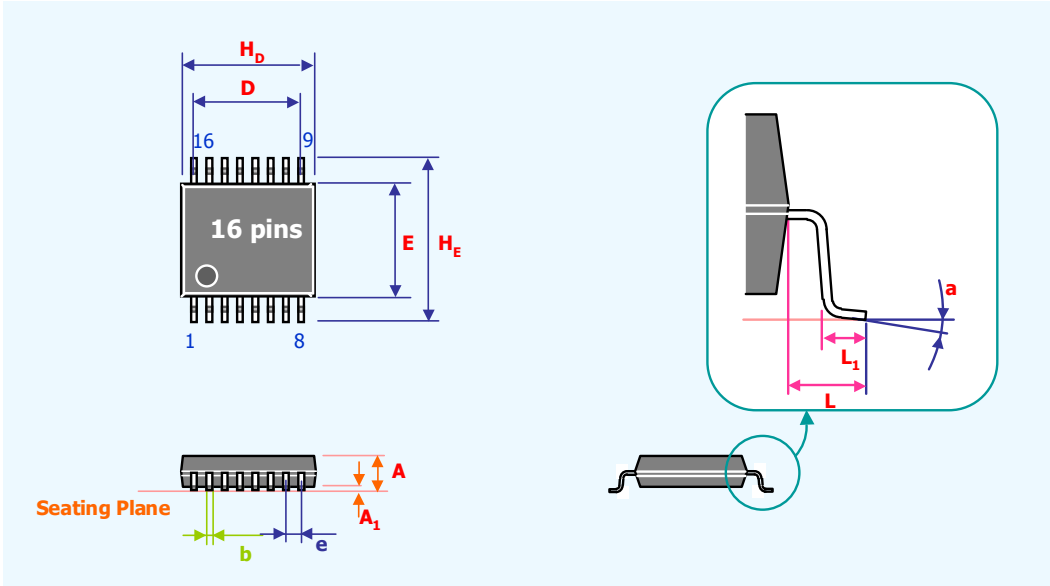

### [16-TSSOP]

Symbol	Dimension in Inches			Dimension in mm		
	Min.	Nom.	Max.	Min.	Nom.	Max.
A	0.037	0.039	0.041	0.95	1.00	1.05
A <sub>1</sub>	0.015	0.017	0.019	0.38	0.44	0.49
b	0.008	0.009	0.011	0.20	0.22	0.24
D	0.176	0.179	0.182	4.47	4.55	4.63
E	0.171	0.173	0.175	4.35	4.40	4.45
H <sub>D</sub>	0.200	0.202	0.204	5.08	5.13	5.18
H <sub>E</sub>	0.248	0.252	0.248	6.30	6.40	6.30
L	0.033	0.037	0.041	0.85	0.95	1.05
L <sub>1</sub>	0.020	0.024	0.028	0.50	0.60	0.70
a	1°	3°	5°	0°	3°	8°
e	0.022	0.026	0.030	0.55	0.65	0.75

**Notes:**

1. Dimension D & E include mold mismatch and are determined at the mold parting line.
2. General appearance spec. should be based on final visual inspection spec.

## 5.2 MLF 20 package

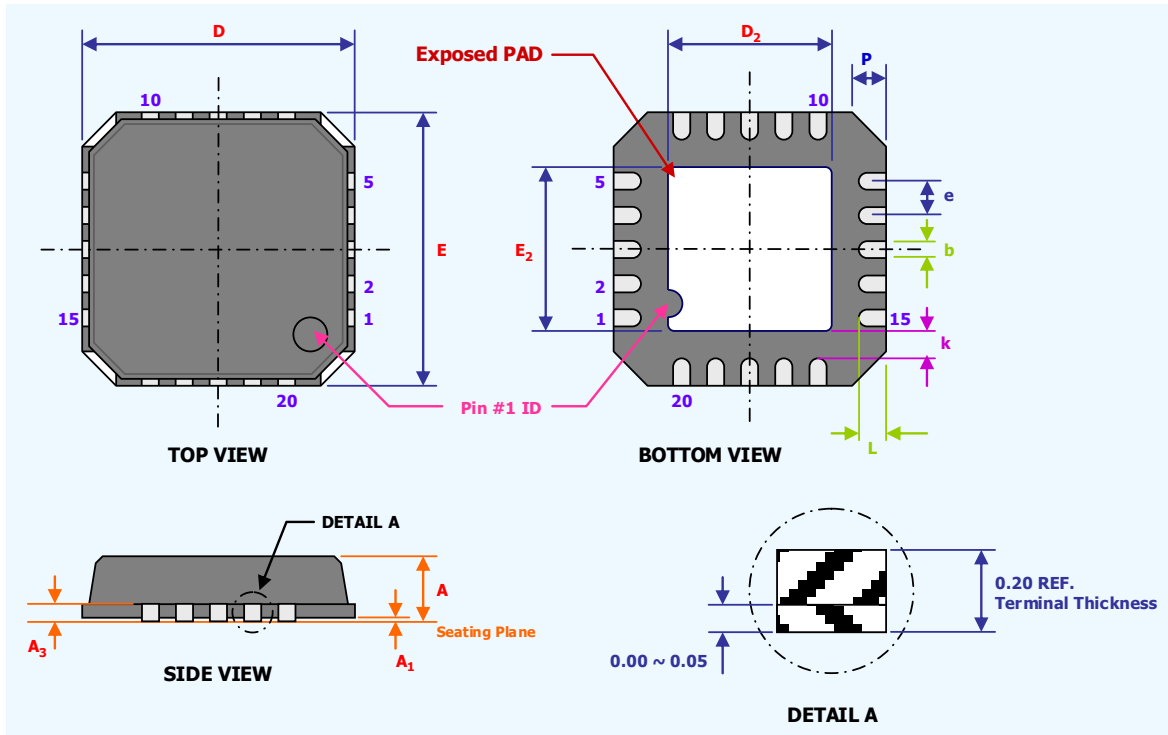

### [20-MLF]

Symbol	Dimension in mm		
	Min.	Nom.	Max.
A	0.80	0.85	0.90
A <sub>1</sub>	0.00	0.01	0.05
A <sub>3</sub>	0.20 REF		
D	5.00 BSC		
E	5.00 BSC		
D <sub>2</sub>	3.00	3.10	3.20
E <sub>2</sub>	3.00	3.10	3.20
b	0.23	0.28	0.35
e	0.65 REF		
L	0.50	0.60	0.75
K	0.20	-	-
P	0.24	0.42	0.60

#### Notes:

1. All Dimension are in mm. Angles in Degrees.
2. Dimension b applies to Plated Terminal & is measured.
3. BSC : Basic Dimension. Theoretically exact value shown without tolerance.  
REF : Reference Dimension, Usually without tolerance, for information purpose only.