TouchCore351-ML16IP

Capacitive Touch Sensor Controller

CORERIVER Semiconductor reserves the right to make corrections, modifications, enhancements, improvements, and other changes to its products and services at any time.

- ◆ *To discontinue any product or service, CORERIVER should inform customers of that before 3 months through its homepage.*
- ◆ *Customers should obtain the latest relevant information before placing orders and should verify that such information is current and complete.*
- ◆ *The CORERIVER Semiconductor products listed in this document are intended for usage in general electronics applications. These CORERIVER Semiconductor products are neither intended nor warranted for usage in equipment that requires extraordinarily high quality and/or reliability or a malfunction or failure of which may cause loss of human life or bodily injury.*

Copyright CORERIVER Semiconductor Co., Ltd. 2012
All Rights Reserved

1 TouchCore351-ML16IP Overview

1.1 General Description

TouchCore351-ML16IP is a high-performance Controller for capacitive touch keys. Its engine is an 8-bit 80C51 compatible Processor.

TouchCore351-ML16IP has three timer/counters, maximum 8-channel of touch sensors, maximum 12 programmable I/O pins, 4-channel 8-bit PWMs, 1 Watchdog timer, POR (Power-On Reset), UART, I²C, 2-channel 12-bit ADC and LVD (Low Voltage Detector) as peripherals. In addition, it contains an internal ring oscillator, which can generate the 48 MHz system clock signal instead of a crystal oscillator.

TouchCore351-ML16IP has its own architecture for fast sensing. With the hardware filter, it provides noise immunity and excellent sensitivity. The firmware algorithm supports smart sensitivity and compensates for changes in the sensitivity due to environmental factors such as temperature and humidity.

To effectively manage power, **TouchCore351-ML16IP** enables low power consumption by using scan interval and clock control methods after last touch.

TouchCore351-ML16IP operates over the extended -20°C to +85°C temperature range, and is available in the 4mm x 4mm, 0.85T, 16-pin MLF package.

1.2 Features

- ◆ Capacitive touch key controller
 - Supports up to 8 single-type touch keys
 - Supports scroll bar-type touch keys
 - Supports wheel-type touch keys
- ◆ Response Time
 - Initial latency of < 20ms for first touch, subject to configuration
 - Programmable sensing rate for power saving.
- ◆ CPU
 - 8-bit Turbo 80C52 Architecture

- 4 Cycles / 1 Machine Cycle
- Instruction Level Compatible with Intel 80C52
- ◆ Memory
 - 8KB Flash (Including 1KB User EEPROM)
 - 512B Internal Aux. RAM
 - 256B Internal RAM
- ◆ Power Supply
 - Operating Voltage : +2.7V to +3.6V
- ◆ Operating Frequency: Max. 48MHz
- ◆ 12 Programmable I/O Pins
- ◆ 4-channel 8-bit PWMs
- ◆ Communication interfaces
 - 1-channel I2C Communication (Master/Slave)
 - 1-channel UART Communication
- ◆ 2-channel 12-bit ADC
- ◆ Internal Ring OSC with Calibration function
- ◆ Supporting ISP/IAP/MDS
- ◆ 8 Internal Interrupt Sources and 4 External Interrupt Sources
- ◆ 4 Reset Sources
- ◆ Power Down Wake-up Sources
 - Reset Sources + 4 External Interrupt (Both Levels)
 - Watchdog Timer Interrupt
- ◆ 3 operating modes : Active, Sleep, Deep Sleep
- ◆ E.S.D. Protection up to
 - 8,000V
- ◆ Latch-up Protection Up to $\pm 200\text{mA}$
- ◆ Package
 - 16-MLF (4mm X 4mm, 0.85T)

1.3 Applications

- ◆ Home appliance: TV, Monitor, Home Theater
- ◆ Mobile Phones
- ◆ Portable MP3, MP4
- ◆ Digital Cameras
- ◆ Battery power applications

1.4 Product Family Guide

Product	Touch Channels	Flash [Byte]	Package
TouchCore320-ML16IP	2	8k	4 x 4 mm, 0.85T, 16-pin MLF
TouchCore350-TS20IP	8	8k	20-pin TSSOP
TouchCore350-QF16IP	8	8k	3 x 3 mm, 0.85T, 16-pin QFN
TouchCore350-ML16IP	8	8k	4 x 4mm, 0.85T, 16-pin MLF
TouchCore351-ML16IP	8	8k	4 x 4 mm, 0.85T, 16-pin MLF
TouchCore360-QF16IP	7	12k	3 x 3 mm, 0.55T, 16-pin QFN
TouchCore370-ML24IP	8	12k	4 x 4 mm, 0.85T, 24-pin MLF
TouchCore371-ML24IP	8	12k	4 x 4 mm, 0.85T, 24-pin MLF
TouchCore380-TS28IP	16	16k	28-pin TSSOP
TouchCore380-SO28IP	16	16k	28-pin SOP
TouchCore380-ML24IP	16	16k	4 x 4 mm, 0.85T, 24-pin MLF
TouchCore390-ML32IP	16	32k	5 x 5 mm, 0.85T, 32-pin MLF

2 Block Diagram

Figure shows the block diagram of **TouchCore351-ML16IP**. Programs reside in the internal program memory (Embedded Flash Memory). Data are read from or written to data memory (SRAM) or special function registers (SFRs).

The internal registers of **TouchCore351-ML16IP** are configured as part of the on-chip RAM: therefore each register has an address. This is reasonable for **TouchCore351-ML16IP**, since it has so many registers.

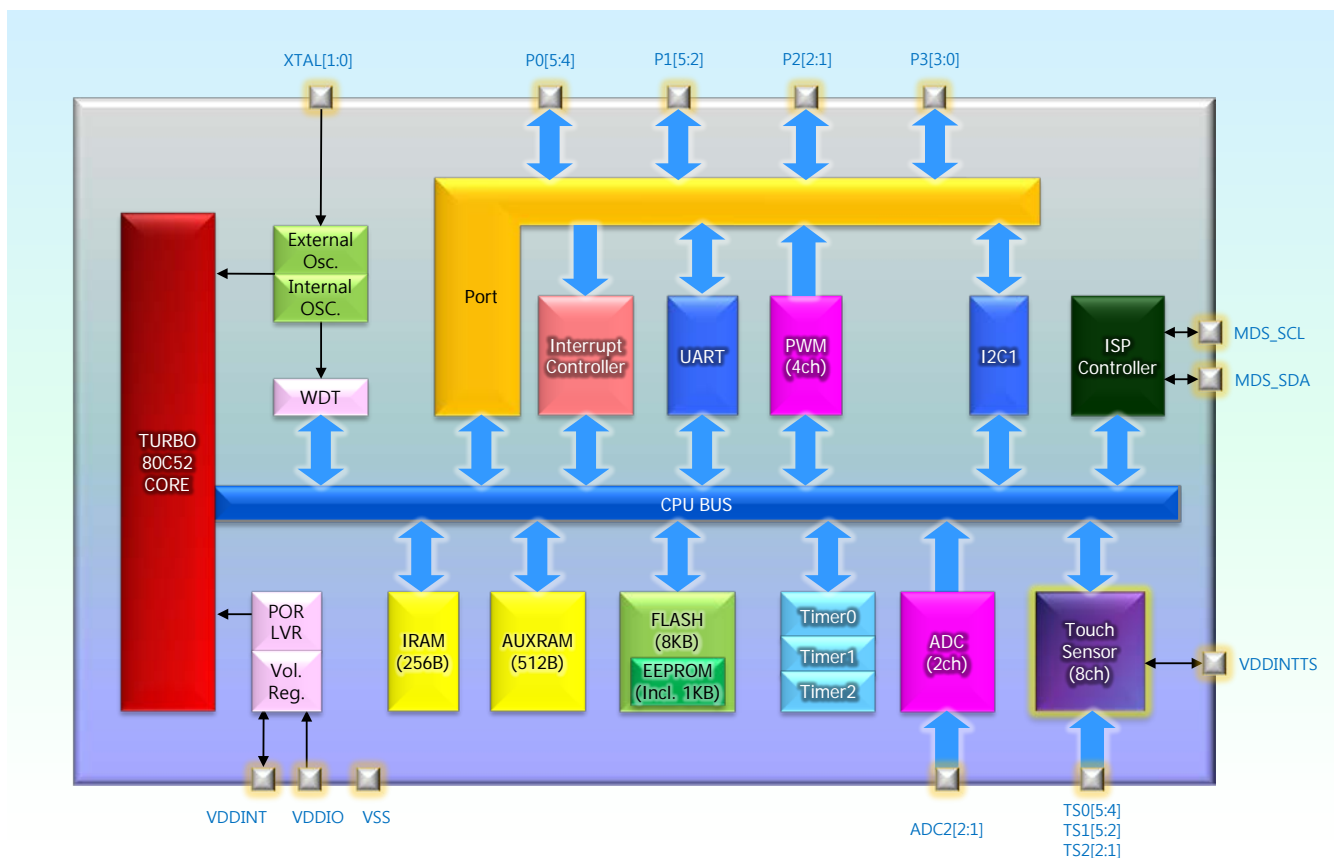

3 Pin Configuration

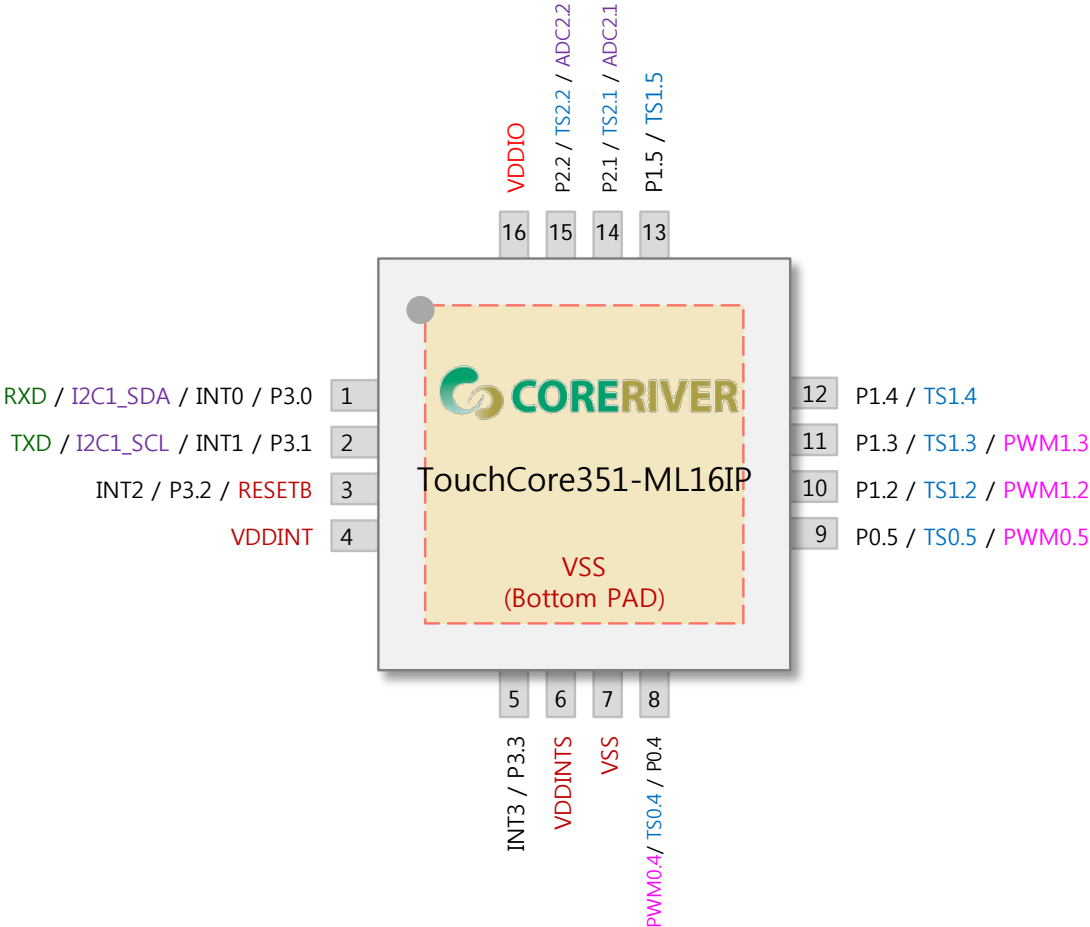

16-pin MLF Package Diagram

4 Pin Description

Pin No.	Name	Type	Description	Share Pins
1	P3.0	I/O	General I/O Port 3.0	RXD / I2C1_SDA / INT0
2	P3.1	I/O	General I/O Port 3.1	TXD / I2C1_SCL / INT1
3	P3.2	I/O	General I/O Port 3.2	INT2 / RESETB
4	VDDINT	O	Digital Power Filter(+1.8V)	
5	P3.3	I/O	General I/O Port 3.3	INT3
6	VDDINTS	O	Touch Sensor Power Filter	
7	VSS	GND		
8	TS0.4	I/O	Touch Sensing Channel 0.4	P0.4 / PWM0.4
9	TS0.5	I/O	Touch Sensing Channel 0.5	P0.5 / PWM0.5
10	TS1.2	I/O	Touch Sensing Channel 1.2	P1.2 / PWM1.2
11	TS1.3	I/O	Touch Sensing Channel 1.3	P1.3 / PWM1.3
12	TS1.4	I/O	Touch Sensing Channel 1.4	P1.4
13	TS1.5	I/O	Touch Sensing Channel 1.5	P1.5
14	TS2.1	I/O	Touch Sensing Channel 2.1	P2.1 / ADC2.1
15	TS2.2	I/O	Touch Sensing Channel 2.2	P2.2 / ADC2.2
16	VDDIO	PWR		

5 Absolute Maximum Ratings

.Absolute Maximum Ratings(TA = 25 °C)

Item	Conditions	Range
DC Voltage in V _{DDIO} relative to Ground	-	-0.5 V to +4.6V
DC Input Voltage	-	-0.5V to (V _{DDIO} +0.5V)
DC Output Voltage	-	-0.5 V to (V _{DDIO} +0.5V)
DC Output Current High	One I/O pin active	-25mA
	All I/O pin active	-100mA
DC Output Current Low	One I/O pin active	+30mA
	All I/O pin active	+150mA
Storage Temperature	-	-65 °C to +150 °C
Soldering Temperature	-	260 °C for 10 seconds

.Recommended Operating Conditions

Item	Conditions	Range
Operating Voltage	-	+2.7 V to +3.6V
Operating Temperature	-	-20 °C to + 85 °C

6 DC Characteristics

* $T_A = -20^{\circ}\text{C} \sim +85^{\circ}\text{C}$, $V_{DDIO} = 2.7\text{V} \sim 3.6\text{V}$ unless otherwise specified

Parameter	Symbol	Pin	Conditions	Value			Unit
				Min.	Typ.	Max.	
Input Low Voltage	V_{IL}	P0,P1,P2,P3	$V_{DDIO} = 2.7\text{V} \sim 3.6\text{V}$	-0.5	-	$0.2V_{DDIO} + 0.1$	V
Input high Voltage	V_{IH}	P0,P1,P2,P3	$V_{DDIO} = 2.7\text{V} \sim 3.6\text{V}$	$0.2V_{DDIO} + 1.0$	-	$V_{DDIO} + 0.5$	V
Output Low Voltage	V_{OL}	P0,P1,P2,P3	$V_{DDIO} = 3.0\text{V} \sim 3.6\text{V}$ ($I_{OL} = 4.35\text{mA}$) $V_{DDIO} = 2.7\text{V} \sim 3.0\text{V}$ ($I_{OL} = 3.55\text{mA}$)	-	-	$0.3V_{DDIO}$	V
		P0,P1,P2,P3[1:0] (High Drive)	$V_{DDIO} = 3.0\text{V} \sim 3.6\text{V}$ ($I_{OL} = 34.79\text{mA}$) $V_{DDIO} = 2.7\text{V} \sim 3.0\text{V}$ ($I_{OL} = 28.41\text{mA}$)	-	-	$0.3V_{DDIO}$	V
Output High Voltage	V_{OH}	P0,P1,P2,P3	$V_{DDIO} = 3.0\text{V} \sim 3.6\text{V}$ ($I_{OH} = -8.04\text{mA}$) $V_{DDIO} = 2.7\text{V} \sim 3.0\text{V}$ ($I_{OH} = -6.62\text{mA}$)	$0.7V_{DDIO}$	-	-	V
	V_{OHP}	P0,P1,P2,P3 (Pull-up Resistor Only)	$V_{DDIO} = 3.0\text{V} \sim 3.6\text{V}$ ($I_{OHP} = -30.30\mu\text{A}$) $V_{DDIO} = 2.7\text{V} \sim 3.0\text{V}$ ($I_{OHP} = -24.26\mu\text{A}$)	$0.7V_{DDIO}$	-	-	V
Logical 1 to 0 Transition Current	I_{TL}	P0,P1,P2,P3	$V_{DDIO} = 3.0\text{V} \pm 10\%$ ($V_{IN} = 2\text{V}$)	-	-	-650	μA
Input Leakage Current	I_{IL}	P0,P1,P2,P3	$V_{IN} = V_{IH}$ or V_{IL}	-	-	± 1	μA
Pin Capacitance	C_{IO}	All	$V_{DDIO} = 3.0\text{V}$	-	10	-	pF

7 AC Characteristics

* $T_A = -20\text{ }^{\circ}\text{C} \sim +85\text{ }^{\circ}\text{C}$, $V_{DDIO} = 2.7\text{V} \sim 3.6\text{V}$ unless otherwise specified

Parameter	Symbol	Pin	Conditions	Value			Unit
				Min	Typ	Max	
RESETB Input Width	t_{RST}	RESETB	$V_{DDIO} = 3\text{V} \pm 10\%$	24	-	-	F_{SYS}
External Interrupt Input Width	t_{INT}	External Interrupt	$V_{DDIO} = 3\text{V} \pm 10\%$	4	-	-	F_{SYS}

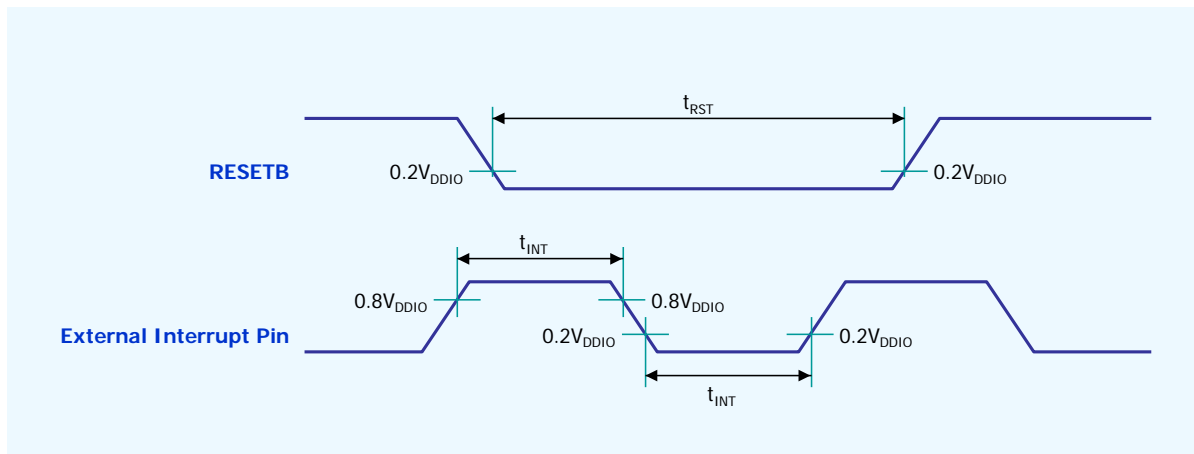

8 I2C Timing Characteristics

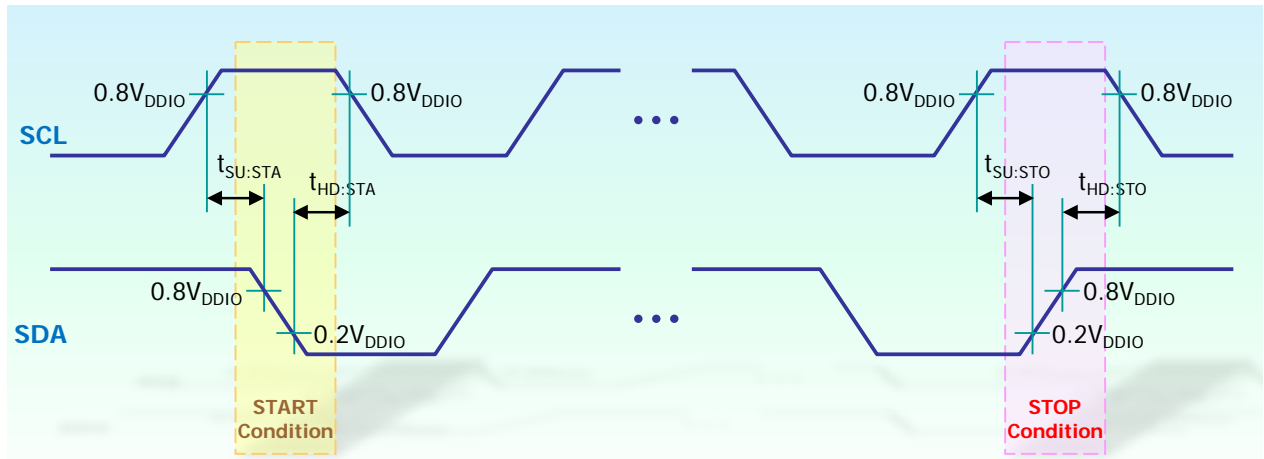

Symbol	Characteristics		Min. [ns]	Max. [ns]	Conditions
$t_{SU:STA}$	START Condition Setup Time	100kHz Mode	4,700	-	Only relevant for repeated START condition
		400kHz Mode	600	-	
$t_{HD:STA}$	START Condition Hold Time	100kHz Mode	4,700	-	After this period, the first clock pulse is generated
		400kHz Mode	600	-	
$t_{SU:STO}$	STOP Condition Setup Time	100kHz Mode	4,700	-	
		400kHz Mode	600	-	
$t_{HD:STO}$	STOP Condition Hold Time	100kHz Mode	4,700	-	
		400kHz Mode	600	-	

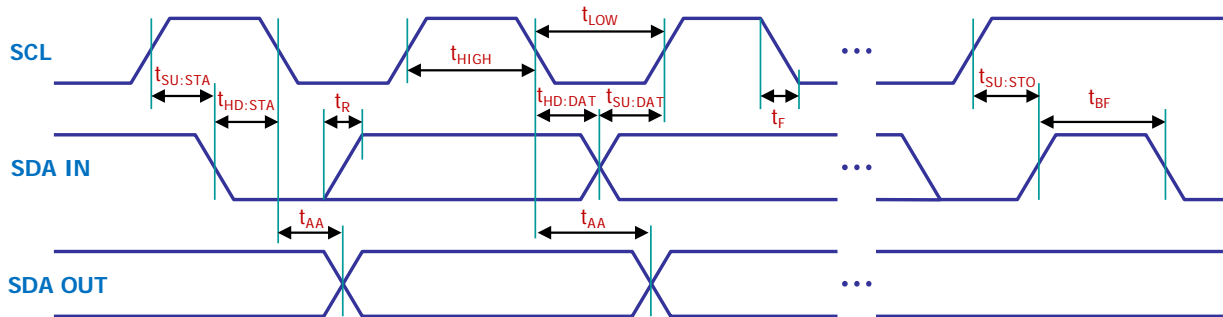

Symbol	Characteristics		Min. [ns]	Max. [ns]	Conditions
t_{HIGH}	Clock High Time	100kHz Mode	4,000	-	Minimum Frequency : 1MHz
		400kHz Mode	600	-	Minimum Frequency : 5MHz
t_{LOW}	Clock Low Time	100kHz Mode	4,700	-	Minimum Frequency : 1MHz
		400kHz Mode	1,300	-	Minimum Frequency : 5MHz
$t_{SU:DAT}$	Data Input Setup Time	100kHz Mode	250	-	
		400kHz Mode	100	-	
$t_{HD:DAT}$	Data Input Hold Time	100kHz Mode	0	-	
		400kHz Mode	0	900	
t_{AA}	Data Valid from Clock	100kHz Mode	-	3,500	
		400kHz Mode	-	-	
t_{BF}	BUS Free Time	100kHz Mode	4,700	-	
		400kHz Mode	1,300	-	
t_R	SDA & SCL Rising Time	100kHz Mode	-	1,000	The Range of Cb is from 10pF to 400pF
		400kHz Mode	$2.0 + 0.1C_b$	300	
t_F	SDA & SCL Falling Time	100kHz Mode	-	300	The Range of Cb is from 10pF to 400pF
		400kHz Mode	$2.0 + 0.1C_b$	300	

9 16-pin MLF Package Dimension

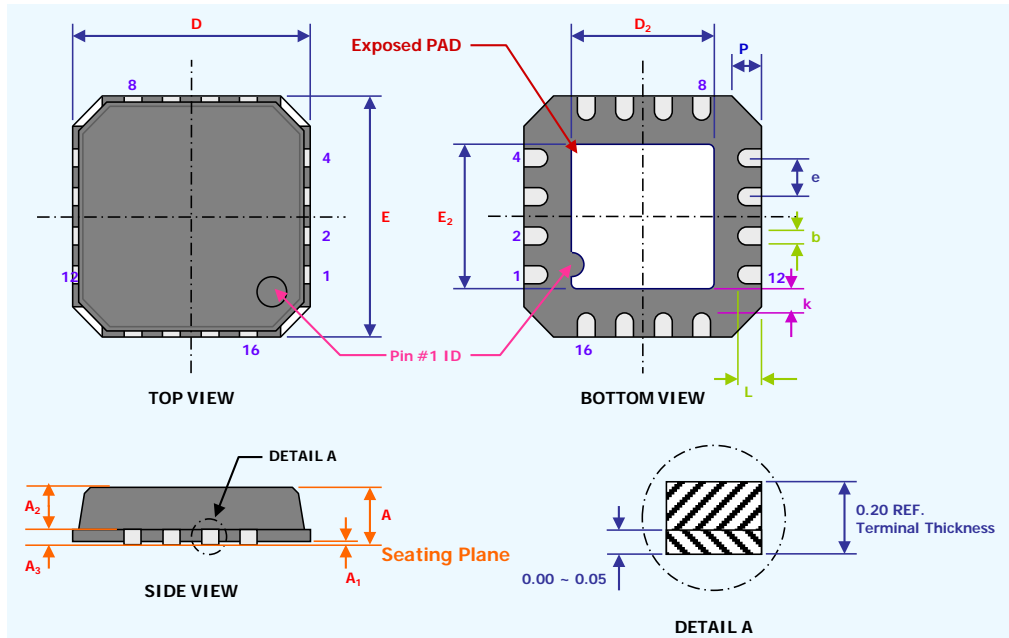

Symbol	Dimensions [mm]		
	Min.	Nom.	Max.
A	0.80	0.85	0.90
A ₁	0.00	0.01	0.05
A ₂	0.60	0.65	0.70
A ₃	0.20 REF		
D	4.00 BSC		
E	4.00 BSC		
D ₂	2.00	2.50	3.00
E ₂	2.00	2.50	3.00
b	0.25	0.35	0.45
e	0.65 BSC		
L	0.30	0.40	0.50
k	0.20	-	-
P	0.24	0.42	0.60

Notes:

1. All Dimension are in mm. Angles in Degrees.
2. Dimension b applies to Plated Terminal & is measured.
3. BSC: Basic Dimension. Theoretically exact value shown without tolerances.
REF: Reference Dimension, Usually without tolerance, for information purpose only.

