

# TouchCore370-ML24IP

## *Capacitive Touch Screen Controller*

---

*CORERIVER Semiconductor reserves the right to make corrections, modifications, enhancements, improvements, and other changes to its products and services at any time.*

- ◆ *To discontinue any product or service, CORERIVER should inform customers of that before 3 months through its homepage.*
- ◆ *Customers should obtain the latest relevant information before placing orders and should verify that such information is current and complete.*
- ◆ *The CORERIVER Semiconductor products listed in this document are intended for usage in general electronics applications. These CORERIVER Semiconductor products are neither intended nor warranted for usage in equipment that requires extraordinarily high quality and/or reliability or a malfunction or failure of which may cause loss of human life or bodily injury.*

**Copyright CORERIVER Semiconductor Co., Ltd. 2012**  
**All Rights Reserved**

# 1 TouchCore370-ML24IP Overview

## 1.1 General Description

**TouchCore370-ML24IP** is a high-performance Touch Controller for capacitive touch keys. Its engine is an 8-bit 80C51 compatible Processor.

**TouchCore370-ML24IP** has three timer/counters, maximum 8-channel of touch sensors, maximum 21 programmable I/O pins, 4-channel 8-bit PWMs, Watchdog timer, POR (Power-On Reset), UART, two I<sup>2</sup>C, SPI and LVD (Low Voltage Detector) as peripherals. In addition, it contains an internal ring oscillator, which can generate the 48 MHz system clock signal instead of a crystal oscillator.

**TouchCore370-ML24IP** has its own architecture for fast sensing. With the hardware filter, it provides noise immunity and excellent sensitivity. The firmware algorithm supports smart sensitivity and compensates for any changes in the sensitivity due to environmental factors such as temperature and humidity.

To effectively manage power, **TouchCore370-ML24IP** enables low power consumption by using scan interval and clock control methods after last touch.

**TouchCore370-ML24IP** operates over the extended -20°C to +85°C temperature range, and is available in the 24-pin MFL package.

## 1.2 Features

- ◆ Capacitive touch key controller
  - Supports up to 8 single-type touch keys
  - Supports scroll bar-type touch keys
  - Supports wheel-type touch keys
- ◆ Response Time
  - Initial latency of < 20ms for first touch, subject to configuration
  - Programmable frame rate for power saving.
- ◆ CPU

- 8-bit Turbo 80C52 Architecture
- 4 Cycles / 1 Machine Cycle
- Instruction Level Compatible with Intel 80C52
- ◆ Memory
  - 12KB Flash (Including 1KB User EEPROM)
  - 512B Internal Aux. RAM
  - 256B Internal RAM
- ◆ Power Supply
  - Operating Voltage : +2.7V to +3.6V
- ◆ Operating Frequency: Max. 48MHz
- ◆ 21 Programmable I/O Pins
- ◆ 4-Channels 8-Bit PWMs
- ◆ Communication interfaces
  - 2-channel I2C Communication (Master/Slave)
  - 1-channel UART Communication
  - 1-channel SPI Communication
- ◆ Internal Ring OSC with Calibration function
- ◆ Supporting ISP/IAP/MDS
- ◆ 9 Internal Interrupt Sources and 5 External Interrupt Sources
- ◆ 4 Reset Sources
- ◆ Power Down Wake-up Sources
  - Reset Sources + 5 External Interrupt (Both Levels)
  - Watchdog Timer Interrupt
- ◆ 3 operating modes : Active, Sleep, Deep Sleep
- ◆ E.S.D. Protection up to
  - 8,000V
- ◆ Latch-up Protection Up to  $\pm 200\text{mA}$
- ◆ Package
  - 24-MLF: 4mm X 4mm, 0.85T

### 1.3 Applications

- ◆ Home appliance: TV, Monitor, Home Theater
- ◆ Mobile Phones
- ◆ Portable MP3, MP4
- ◆ Digital Cameras
- ◆ Navigation Systems & Automotive Applications
- ◆ Battery power applications

### 1.4 Product Family Guide

| Product                    | Touch Channels | Flash [Byte] | Package                            |
|----------------------------|----------------|--------------|------------------------------------|
| TouchCore320-ML16IP        | 2              | 8K           | 4 x 4 mm, 0.85T, 16-pin MLF        |
| TouchCore350-TS20IP        | 8              | 8K           | 20-pin TSSOP                       |
| TouchCore350-QF16IP        | 8              | 8K           | 3 x 3 mm, 0.85T, 16-pin QFN        |
| TouchCore350-ML16IP        | 8              | 8K           | 4 x 4mm, 0.85T, 16-pin MLF         |
| TouchCore351-ML16IP        | 8              | 8K           | 4 x 4 mm, 0.85T, 16-pin MLF        |
| TouchCore360-QF16IP        | 7              | 12K          | 3 x 3 mm, 0.55T, 16-pin QFN        |
| <b>TouchCore370-ML24IP</b> | <b>8</b>       | <b>12K</b>   | <b>4 x 4 mm, 0.85T, 24-pin MLF</b> |
| TouchCore371-ML24IP        | 8              | 12K          | 4 x 4 mm, 0.85T, 24-pin MLF        |
| TouchCore380-TS28IP        | 16             | 16K          | 28-pin TSSOP                       |
| TouchCore380-SO28IP        | 16             | 16K          | 28-pin SOP                         |
| TouchCore380-ML24IP        | 16             | 16K          | 4 x 4 mm, 0.85T, 24-pin MLF        |
| TouchCore390-ML32IP        | 16             | 32k          | 5 x 5 mm, 0.85T, 32-pin MLF        |

## 2 Block Diagram

Figure shows the block diagram of **TouchCore370-ML24IP**. Programs reside in the internal program memory (Embedded Flash Memory). Data are read from or written to data memory (SRAM) or special function registers (SFRs).

The internal registers of **TouchCore370-ML24IP** are configured as part of the on-chip RAM: therefore each register has an address. This is reasonable for **TouchCore370-ML24IP**, since it has so many registers.

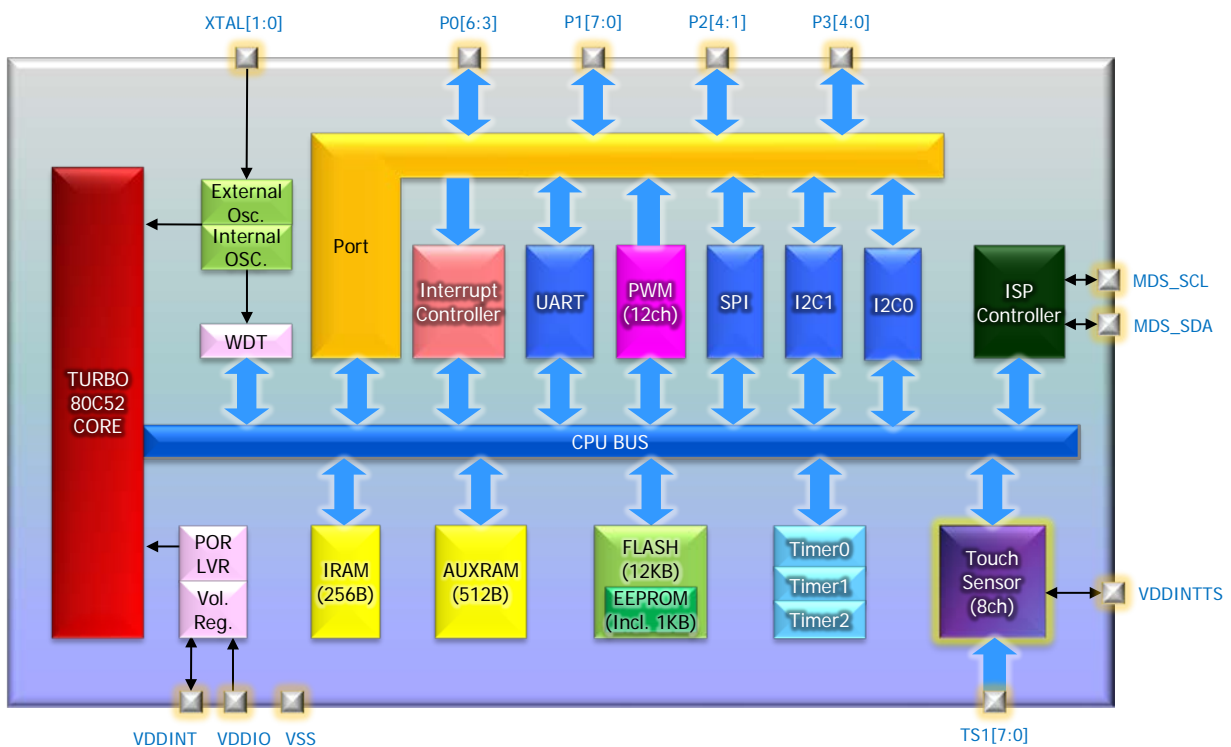

### 3 Pin Configuration

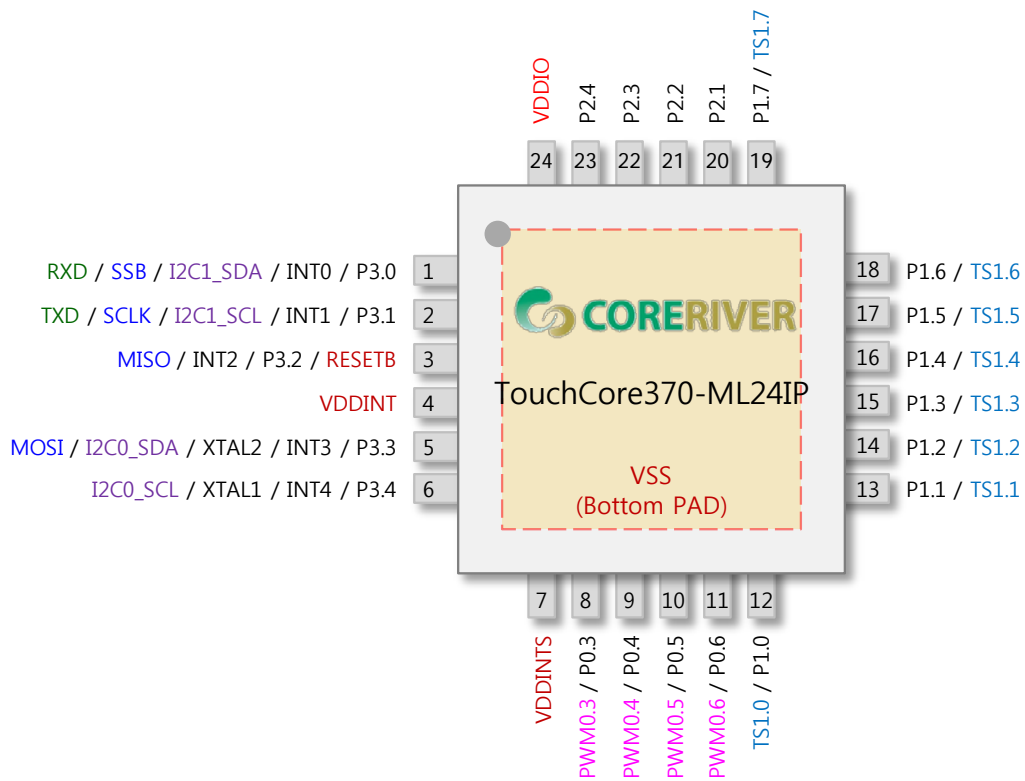

24-pin MLF Package Diagram

## 4 Pin Description

| Pin No. | Name    | Type | Description                    | Share Pins                     |
|---------|---------|------|--------------------------------|--------------------------------|
| 1       | P3.0    | I/O  | General I/O Port 3.0           | RXD / SSB / I2C1_SDA / INT0    |
| 2       | P3.1    | I/O  | General I/O Port 3.1           | TXD / SCLK / I2C1_SCL / INT1   |
| 3       | P3.2    | I/O  | General I/O Port 3.2           | INT2 / RESETB / MISO           |
| 4       | VDDINT  | O    | Digital Power Filter ( +1.8V ) |                                |
| 5       | P3.3    | I/O  | General I/O Port 3.3           | INT3 / XTAL2 / I2C0_SDA / MOSI |
| 6       | P3.4    | I/O  | General I/O Port 3.4           | INT4 / XTAL1 / I2C0_SCL        |
| 7       | VDDINTS | O    | Touch Sensor Power Filter      |                                |
| 8       | P0.3    | I/O  | General I/O Port 0.3           | PWM0.3                         |
| 9       | P0.4    | I/O  | General I/O Port 0.4           | PWM0.4                         |
| 10      | P0.5    | I/O  | General I/O Port 0.5           | PWM0.5                         |
| 11      | P0.6    | I/O  | General I/O Port 0.6           | PWM0.6                         |
| 12      | TS1.0   | I/O  | Touch Sensing Channel 1.0      | P1.0                           |
| 13      | TS1.1   | I/O  | Touch Sensing Channel 1.1      | P1.1                           |
| 14      | TS1.2   | I/O  | Touch Sensing Channel 1.2      | P1.2                           |
| 15      | TS1.3   | I/O  | Touch Sensing Channel 1.3      | P1.3                           |
| 16      | TS1.4   | I/O  | Touch Sensing Channel 1.4      | P1.4                           |
| 17      | TS1.5   | I/O  | Touch Sensing Channel 1.5      | P1.5                           |
| 18      | TS1.6   | I/O  | Touch Sensing Channel 1.6      | P1.6                           |
| 19      | TS1.7   | I/O  | Touch Sensing Channel 1.7      | P1.7                           |
| 20      | P2.1    | I/O  | General I/O Port 2.1           |                                |
| 21      | P2.2    | I/O  | General I/O Port 2.2           |                                |
| 22      | P2.3    | I/O  | General I/O Port 2.3           |                                |
| 23      | P2.4    | I/O  | General I/O Port 2.4           |                                |
| 24      | VDDIO   | PWR  |                                |                                |

## 5 Absolute Maximum Ratings

.Absolute Maximum Ratings( TA = 25 °C )

| Item   | Conditions         | Range                               |
|--|--------------------|-------------------------------------|
| DC Voltage in V <sub>DDIO</sub> relative to Ground | -                  | -0.5 V to +4.6V                     |
| DC Input Voltage                                   | -                  | -0.5V to (V <sub>DDIO</sub> +0.5V)  |
| DC Output Voltage                                  | -                  | -0.5 V to (V <sub>DDIO</sub> +0.5V) |
| DC Output Current High                             | One I/O pin active | -25mA                               |
|  | All I/O pin active | -100mA                              |
| DC Output Current Low                              | One I/O pin active | +30mA                               |
|  | All I/O pin active | +150mA                              |
| Storage Temperature                                | -                  | -65 °C to +150 °C                   |
| Soldering Temperature                              | -                  | 260 °C for 10 seconds               |

.Recommended Operating Conditions

| Item                  | Conditions | Range             |
|-----------------------|------------|-------------------|
| Operating Voltage     | -          | +2.7 V to +3.6V   |
| Operating Temperature | -          | -20 °C to + 85 °C |



## 6 DC Characteristics

\*  $T_A = -20^{\circ}\text{C} \sim +85^{\circ}\text{C}$ ,  $V_{DDIO} = 2.7\text{V} \sim 3.6\text{V}$  unless otherwise specified

| Parameter                         | Symbol    | Pin                                    | Conditions   | Value               |      |                     | Unit          |
|-----------------------------------|-----------|--|--|---------------------|------|---------------------|---------------|
|                                   |           |  |  | Min.                | Typ. | Max.                |               |
| Input Low Voltage                 | $V_{IL}$  | P0,P1,P2,P3                            | $V_{DDIO} = 2.7\text{V} \sim 3.6\text{V}$  | -0.5                | -    | $0.2V_{DDIO} + 0.1$ | V             |
| Input high Voltage                | $V_{IH}$  | P0,P1,P2,P3                            | $V_{DDIO} = 2.7\text{V} \sim 3.6\text{V}$  | $0.2V_{DDIO} + 1.0$ | -    | $V_{DDIO} + 0.5$    | V             |
| Output Low Voltage                | $V_{OL}$  | P0,P1,P2,P3                            | $V_{DDIO} = 3.0\text{V} \sim 3.6\text{V}$<br>( $I_{OL} = 4.35\text{mA}$ )<br>$V_{DDIO} = 2.7\text{V} \sim 3.0\text{V}$<br>( $I_{OL} = 3.55\text{mA}$ )           | -                   | -    | $0.3V_{DDIO}$       | V             |
|                                   |           | P0,P1,P2,P3[1:0]<br>(High Drive)       | $V_{DDIO} = 3.0\text{V} \sim 3.6\text{V}$<br>( $I_{OL} = 34.79\text{mA}$ )<br>$V_{DDIO} = 2.7\text{V} \sim 3.0\text{V}$<br>( $I_{OL} = 28.41\text{mA}$ )         | -                   | -    | $0.3V_{DDIO}$       | V             |
| Output High Voltage               | $V_{OH}$  | P0,P1,P2,P3                            | $V_{DDIO} = 3.0\text{V} \sim 3.6\text{V}$<br>( $I_{OH} = -8.04\text{mA}$ )<br>$V_{DDIO} = 2.7\text{V} \sim 3.0\text{V}$<br>( $I_{OH} = -6.62\text{mA}$ )         | $0.7V_{DDIO}$       | -    | -                   | V             |
|                                   | $V_{OHP}$ | P0,P1,P2,P3<br>(Pull-up Resistor Only) | $V_{DDIO} = 3.0\text{V} \sim 3.6\text{V}$<br>( $I_{OHP} = -30.30\mu\text{A}$ )<br>$V_{DDIO} = 2.7\text{V} \sim 3.0\text{V}$<br>( $I_{OHP} = -24.26\mu\text{A}$ ) | $0.7V_{DDIO}$       | -    | -                   | V             |
| Logical 1 to 0 Transition Current | $I_{TL}$  | P0,P1,P2,P3                            | $V_{DDIO} = 3.0\text{V} \pm 10\%$<br>( $V_{IN} = 2\text{V}$ )  | -                   | -    | -650                | $\mu\text{A}$ |
| Input Leakage Current             | $I_{IL}$  | P0,P1,P2,P3                            | $V_{IN} = V_{IH}$ or $V_{IL}$  | -                   | -    | $\pm 1$             | $\mu\text{A}$ |
| Pin Capacitance                   | $C_{IO}$  | All                                    | $V_{DDIO} = 3.0\text{V}$   | -                   | 10   | -                   | pF            |

## 7 AC Characteristics

\*  $T_A = -20\text{ }^{\circ}\text{C} \sim +85\text{ }^{\circ}\text{C}$ ,  $V_{DDIO} = 2.7\text{V} \sim 3.6\text{V}$  unless otherwise specified

| Parameter                      | Symbol    | Pin                | Conditions                      | Value |     |     | Unit             |
|--------------------------------|-----------|--------------------|---------------------------------|-------|-----|-----|------------------|
|                                |           |                    |                                 | Min   | Typ | Max |                  |
| RESETB Input Width             | $t_{RST}$ | RESETB             | $V_{DDIO} = 3\text{V} \pm 10\%$ | 24    | -   | -   | F <sub>sys</sub> |
| External Interrupt Input Width | $t_{INT}$ | External Interrupt | $V_{DDIO} = 3\text{V} \pm 10\%$ | 4     | -   | -   | F <sub>sys</sub> |

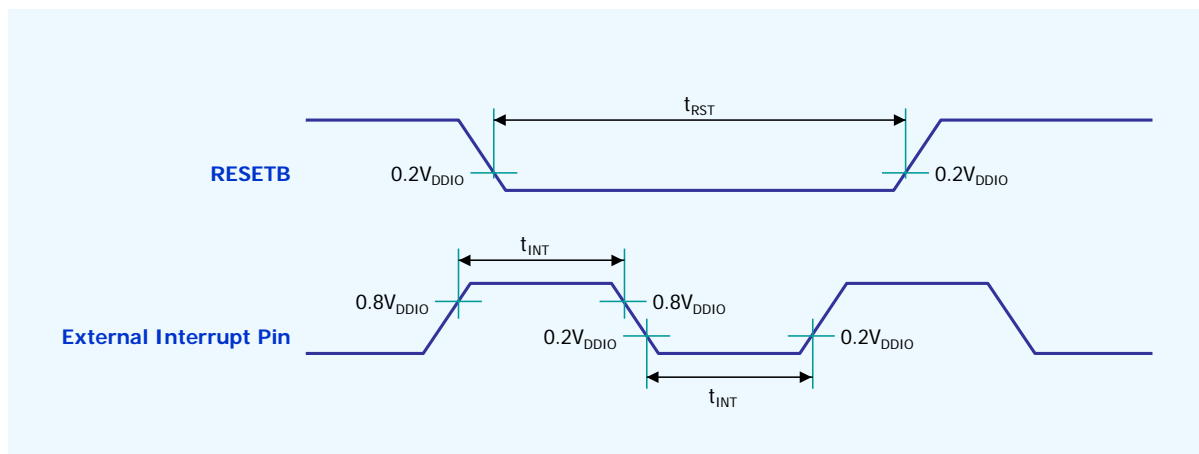

## 8 I2C Timing Characteristics

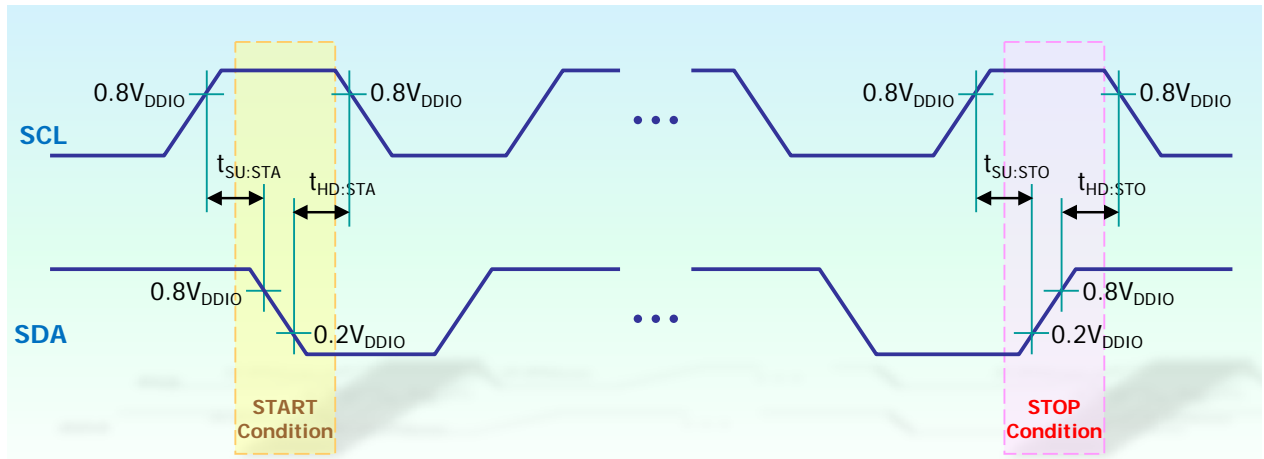

| Symbol       | Characteristics            |             | Min. [ns] | Max. [ns] | Conditions  |
|--------------|----------------------------|-------------|-----------|-----------|---|
| $t_{SU:STA}$ | START Condition Setup Time | 100kHz Mode | 4,700     | -         | Only relevant for repeated START condition            |
|              |                            | 400kHz Mode | 600       | -         |   |
| $t_{HD:STA}$ | START Condition Hold Time  | 100kHz Mode | 4,700     | -         | After this period, the first clock pulse is generated |
|              |                            | 400kHz Mode | 600       | -         |   |
| $t_{SU:STO}$ | STOP Condition Setup Time  | 100kHz Mode | 4,700     | -         |   |
|              |                            | 400kHz Mode | 600       | -         |   |
| $t_{HD:STO}$ | STOP Condition Hold Time   | 100kHz Mode | 4,700     | -         |   |
|              |                            | 400kHz Mode | 600       | -         |   |

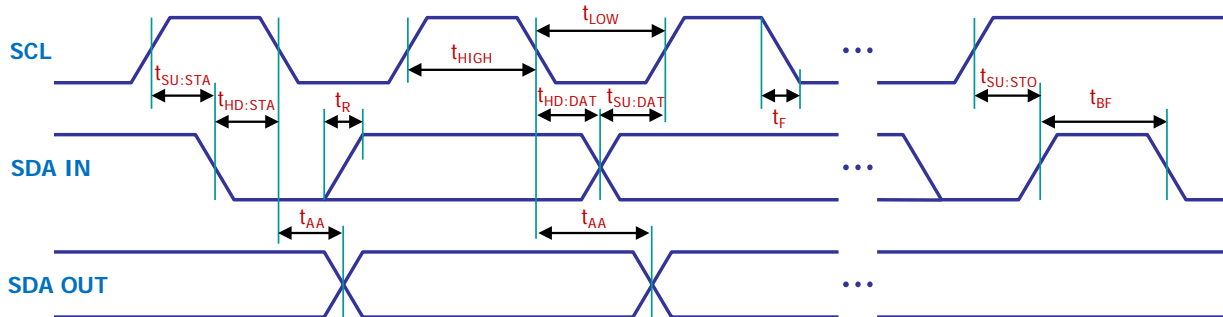

| Symbol       | Characteristics        |             | Min. [ns]      | Max. [ns] | Conditions                            |
|--------------|------------------------|-------------|----------------|-----------|---------------------------------------|
| $t_{HIGH}$   | Clock High Time        | 100kHz Mode | 4,000          | -         | Minimum Frequency : 1MHz              |
|              |                        | 400kHz Mode | 600            | -         | Minimum Frequency : 5MHz              |
| $t_{LOW}$    | Clock Low Time         | 100kHz Mode | 4,700          | -         | Minimum Frequency : 1MHz              |
|              |                        | 400kHz Mode | 1,300          | -         | Minimum Frequency : 5MHz              |
| $t_{SU:DAT}$ | Data Input Setup Time  | 100kHz Mode | 250            | -         |                                       |
|              |                        | 400kHz Mode | 100            | -         |                                       |
| $t_{HD:DAT}$ | Data Input Hold Time   | 100kHz Mode | 0              | -         |                                       |
|              |                        | 400kHz Mode | 0              | 900       |                                       |
| $t_{AA}$     | Data Valid from Clock  | 100kHz Mode | -              | 3,500     |                                       |
|              |                        | 400kHz Mode | -              | -         |                                       |
| $t_{BF}$     | BUS Free Time          | 100kHz Mode | 4,700          | -         |                                       |
|              |                        | 400kHz Mode | 1,300          | -         |                                       |
| $t_R$        | SDA & SCL Rising Time  | 100kHz Mode | -              | 1,000     | The Range of Cb is from 10pF to 400pF |
|              |                        | 400kHz Mode | $2.0 + 0.1C_b$ | 300       |                                       |
| $t_F$        | SDA & SCL Falling Time | 100kHz Mode | -              | 300       | The Range of Cb is from 10pF to 400pF |
|              |                        | 400kHz Mode | $2.0 + 0.1C_b$ | 300       |                                       |

## 9 SPI Timing Characteristics

### 9.1 Master Mode

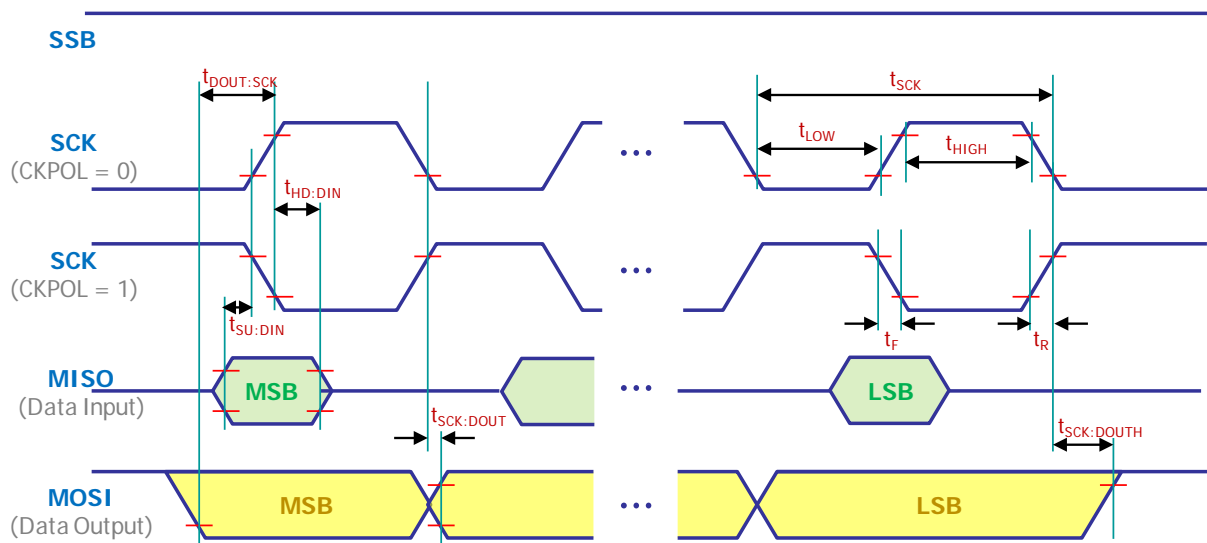

| Symbol              | Description                         | Mode   | Min. [ns] | Typ. [ns]                    | Max. [ns] |
|---------------------|-------------------------------------|--------|-----------|------------------------------|-----------|
| $t_{SCK}$           | SCK Period Time (using SFR 'SPICK') | Master | -         | $F_{osc}/2 \sim F_{osc}/256$ | -         |
| $t_{HIGH}, t_{LOW}$ | SCK High / Low                      | Master | -         | 50% Duty Cycle               | -         |
| $t_F, t_R$          | SCK Rise / Fall Time                | Master | -         | 3.6                          | -         |
| $t_{SU: DIN}$       | Data Input Setup Time               | Master | -         | 10                           | -         |
| $t_{HD: DIN}$       | Data Input Hold Time                | Master | -         | 10                           | -         |
| $t_{DOUT:SCK}$      | Data Output to SCK                  | Master | -         | $0.5 \times t_{SCK}$         | -         |
| $t_{SCK: DOUT}$     | SCK to Data Output                  | Master | -         | 10                           | -         |
| $t_{SCK: DOUTH}$    | SCK to Data Output High             | Master | -         | 10                           | -         |

## 9.2 Slave Mode

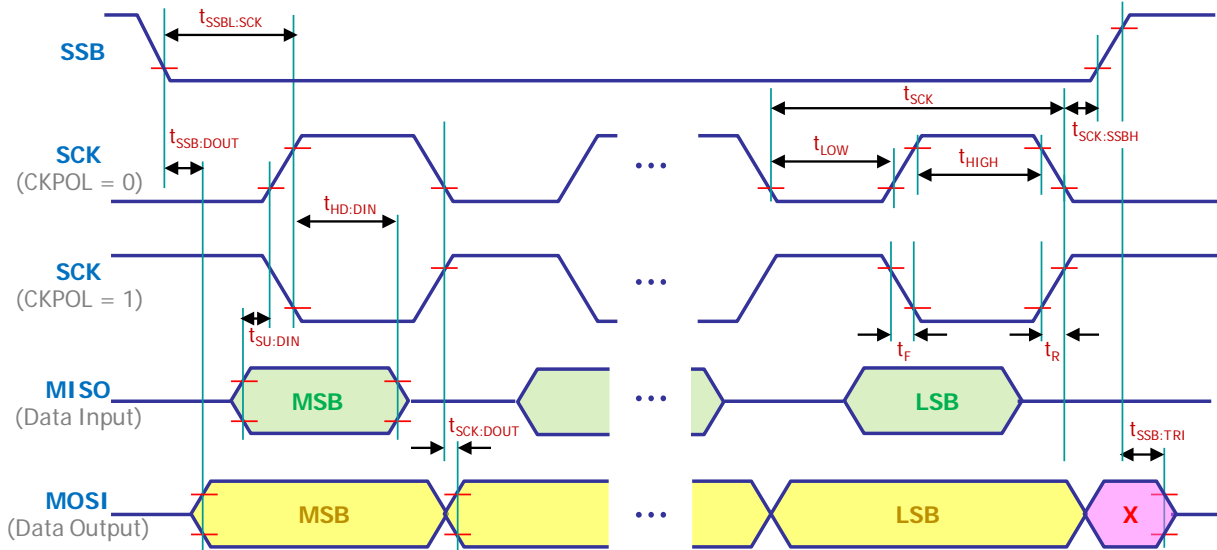

| Symbol              | Description            | Mode  | Min. [ns]          | Typ. [ns] | Max. [ns] |
|---------------------|------------------------|-------|--------------------|-----------|-----------|
| $t_{SSB:DOUT}$      | SSB Low to Data Output | Slave | -                  | 15        | -         |
| $T_{SCK}$           | SCK Period Time        | Slave | $4 \times t_{sys}$ | -         | -         |
| $t_{HIGH}, t_{LOW}$ | SCK High / Low         | Slave | $2 \times t_{sys}$ | -         | -         |
| $t_F, t_R$          | SCK Rise / Fall Time   | Slave | -                  | 1,600     | -         |
| $t_{SU:DIN}$        | Data Input Setup Time  | Slave | 10                 | -         | -         |
| $t_{HD:DIN}$        | Data Input Hold Time   | Slave | $t_{sys}$          | -         | -         |
| $t_{SCK:DOUT}$      | SCK to Data Output     | Slave | -                  | 15        | -         |
| $t_{SCK:SSBH}$      | SCK to SSB High        | Slave | 20                 | -         | -         |
| $t_{SSB:TRI}$       | SSB High to Tri-state  | Slave | -                  | 10        | -         |
| $t_{SSBL:SCK}$      | SSB Low to SCK         | Slave | 20                 | -         | -         |

## 10 24-pin MLF Package Dimension

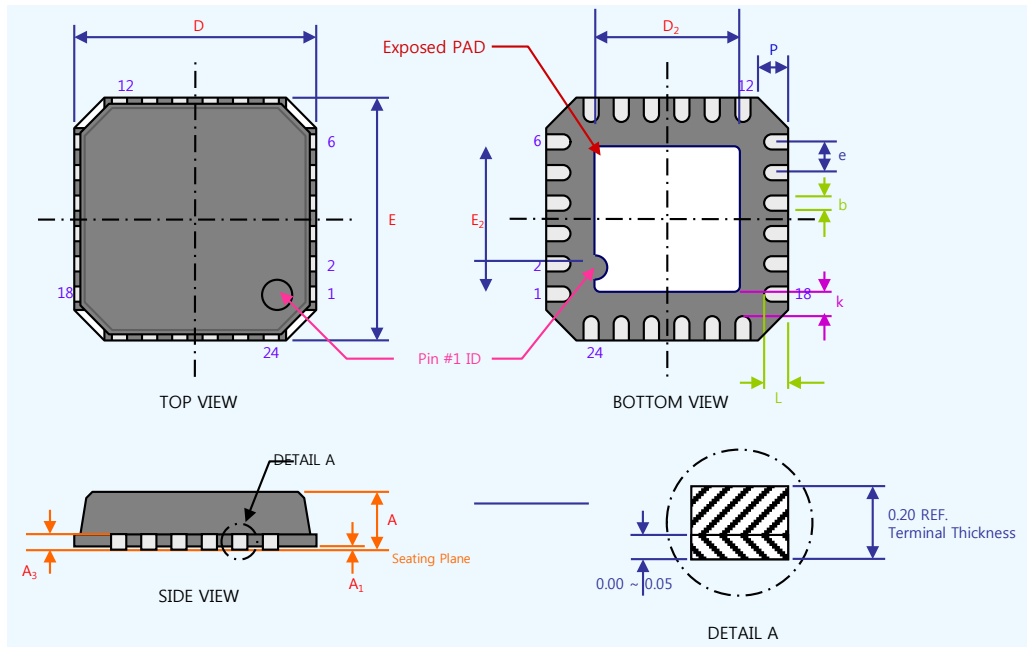

| Symbol         | Dimension in mm |      |      |
|----------------|-----------------|------|------|
|                | Min.            | Nom. | Max. |
| A              | 0.80            | 0.85 | 0.90 |
| A <sub>1</sub> | 0.00            | 0.01 | 0.05 |
| A <sub>3</sub> | 0.20 REF        |      |      |
| D              | 4.00 BSC        |      |      |
| E              | 4.00 BSC        |      |      |
| D <sub>2</sub> | 2.40            | 2.50 | 2.60 |
| E <sub>2</sub> | 2.40            | 2.50 | 2.60 |
| b              | 0.18            | 0.23 | 0.30 |
| e              | 0.50 BSC        |      |      |
| L              | 0.30            | 0.40 | 0.50 |
| k              | 0.20            | -    | -    |
| P              | 0.24            | 0.42 | 0.60 |

### Notes:

- All Dimension are in mm. Angles in Degrees.
- Dimension b applies to Plated Terminal & is measured.
- BSC : Basic Dimension. Theoretically exact value shown without tolerances.  
REF : Reference Dimension, Usually without tolerance, for information purpose only.

# TouchCore370\_MLF24

Body Size : 4mm x 4mm

>> VDDIO ( Operating Voltage ) : +2.7V to +3.6V

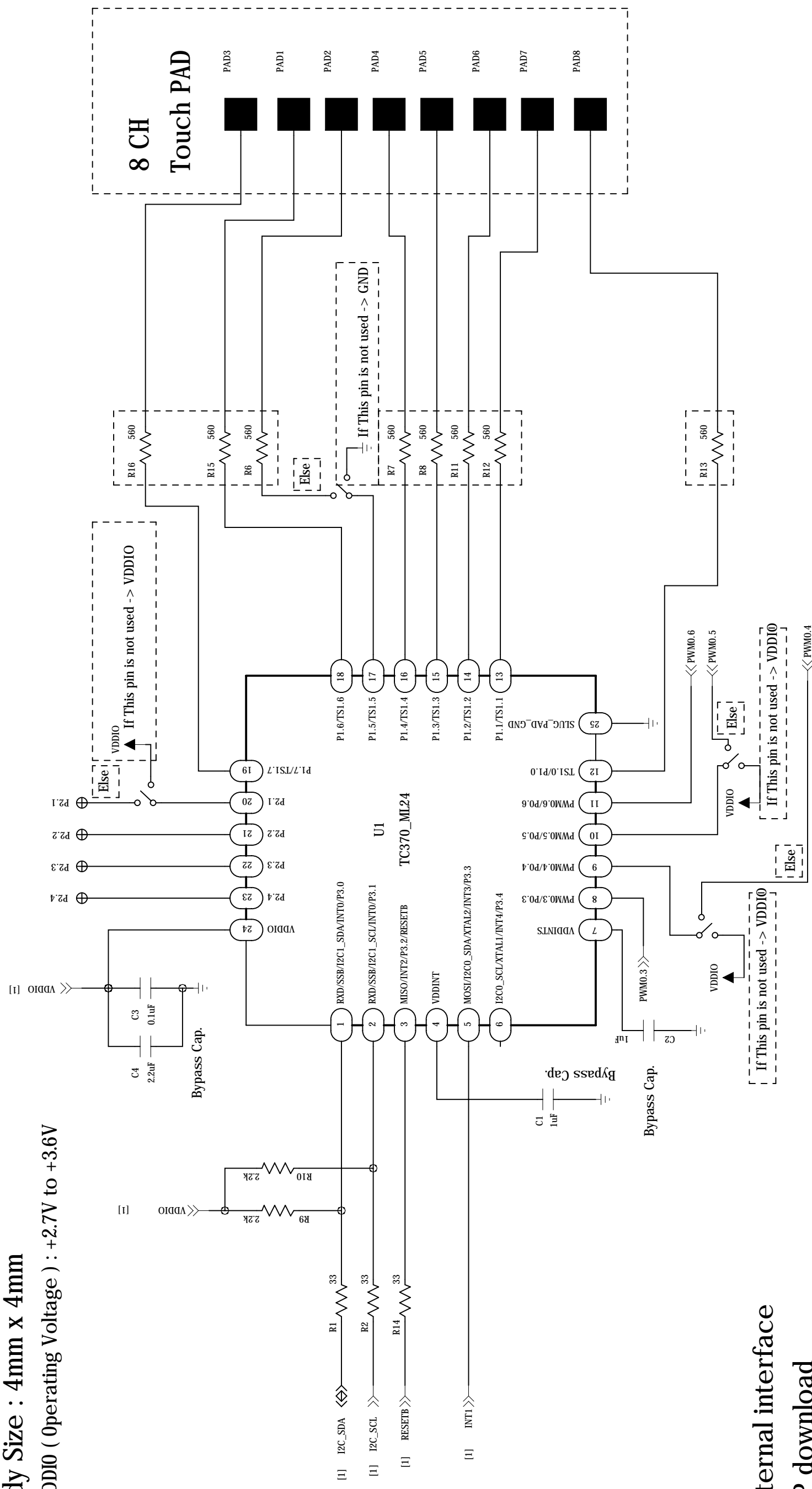

## External interface

## ISP download

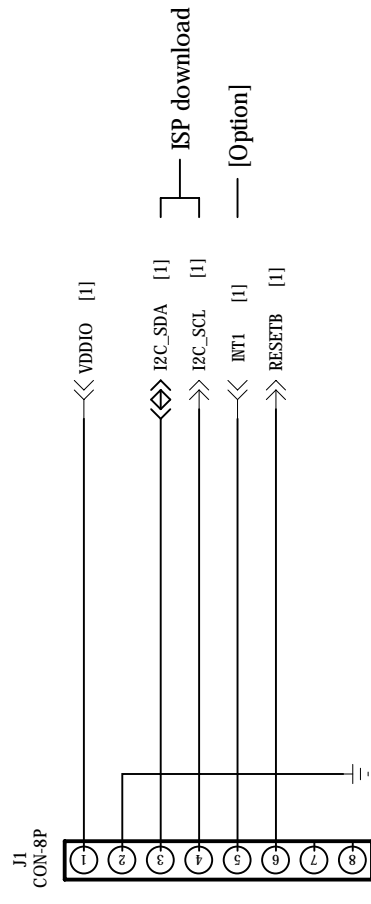

| NO. | REVISION NO. | NO. | REVISION NO. | QUANTITY |      |       | PART NO.   | DESCRIPTION     | MATERIAL    | COLOR FINISH | NOTE |
|-----|--------------|-----|--------------|----------|------|-------|------------|-----------------|-------------|--------------|------|
|     |              |     |              | C        | B    | A     |            |                 |             |              |      |
| 1   |              |     |              |          |      |       |            |                 |             |              |      |
| 2   |              |     |              |          |      |       |            |                 |             |              |      |
|     |              |     |              | SCALE    | UNIT |       | DRAWN.     |                 |             |              |      |
|     |              |     |              | A3       | mm   |       | 2014-07-21 |                 | D'SCHEMATIC |              |      |
|     |              |     |              | 1 / 1    |      | mm    |            | TC370_MLF24_4X4 |             |              |      |
|     |              |     |              | SHEET    |      | 1 / 1 |            | CORERIVER       |             |              |      |