GC221-S016IP

8-bit Turbo Microcontroller

CORERIVER Semiconductor reserves the right to make corrections, modifications, enhancements, improvements, and other changes to its products and services at any time.

- ◆ *To discontinue any product or service, CORERIVER should inform customers of that before 3 months through its homepage.*
- ◆ *Customers should obtain the latest relevant information before placing orders and should verify that such information is current and complete.*
- ◆ *The CORERIVER Semiconductor products listed in this document are intended for usage in general electronics applications. These CORERIVER Semiconductor products are neither intended nor warranted for usage in equipment that requires extraordinarily high quality and/or reliability or a malfunction or failure of which may cause loss of human life or bodily injury.*

Copyright CORERIVER Semiconductor Co., Ltd. 2018
All Rights Reserved

1 GC221-SO16IP Overview

1.1 General Description

GC221-SO16IP is a high-speed 80C52 compatible Microcontroller. It executes all of the conventional 80C52 instructions.

GC221-SO16IP has three timer/counters, 14 programmable I/O ports, Watchdog timer, Stop timer, POR (Power-On Reset), UARTs, I²Cs, and LVD (Low Voltage Detector) as peripherals. In addition, it contains an internal precision oscillator, which can generate the 12 MHz system clock signal instead of a crystal oscillator.

GC221-SO16IP operates over the extended -40°C to +85°C temperature range, and is available in the 16-pin SOP package.

1.2 Features

- ◆ CPU
 - ✓ 8-bit turbo 80C52 architecture
 - ✓ 4 cycles/1 machine cycle
 - ✓ instruction level compatible with Intel 80C52
- ◆ 4 KB FLASH (Including 128B User EEPROM)
- ◆ Supporting ISP/IAP/MDS
- ◆ 128B Internal RAM
- ◆ Operating Voltage : +2.2V to +5.5V
- ◆ Operating Frequency (F_{sys})
 - ✓ 3.68 MHz (Internal POSC Clock, Default)
 - ✓ Max. 12 / 11.06 MHz @2.2V ~ 3.3V (External/Internal POSC Clock)
 - ✓ Max. 24 MHz @4.5V ~ 5.5V (External Clock)
- ◆ Operating temperature : -40 °C ~ 85 °C
- ◆ 14 Programmable I/O Pins
 - ✓ Pull-up control, Open drain, & Push-Pull output
 - ✓ TTL and CMOS compatible logic levels

- ◆ **Configurable Low Voltage Detector (LVD)**
- ◆ **Internal Precision OSC with Calibration function**
 - ✓ 11.06 MHz @+2.2V to +5.5V (Typ. +/- 1%)
 - ✓ 32kHz @+2.7V (+/- 10%) : Low Power OSC.
- ◆ **12-channel 10-bit ADC**
 - ✓ Max. 120k SPS @ $F_{ADC} = 12$ MHz ($F_{SYS} = 12$ MHz)
 - ✓ Programmable Input Clock Frequency
- ◆ **23-bit Programmable Watchdog Timer**
- ◆ **16-bit Stop Timer**
- ◆ **Two 16-bit Timer/Counters**
- ◆ **Full-Duplex 1-channel UART Comm.**
- ◆ **1-channel I2C Comm. (I2C Slave)**
- ◆ **1-channel 10-bit high speed PWM**
- ◆ **12 Interrupt Sources**
 - ✓ Timer0/1, WDT, LVD, ADC, UART, PWM, I2C1
 - ✓ 4 External Interrupt Sources: Both Edge/Level
 - ✓ Two-level Interrupt Priority
- ◆ **Reset Sources**
 - ✓ On-chip Power-On-Reset (POR/LVR)
 - ✓ External Reset
 - ✓ Configurable Low Voltage Detector Reset
 - ✓ Watchdog Timer Reset
- ◆ **Power Down Wake-up Sources**
 - ✓ Reset Sources + 4 External Interrupt (Both Levels)
 - ✓ I2C Interrupt or WDT Interrupt
 - ✓ Stop Timer wake-up
- ◆ **Power Consumption**
 - ✓ Active Current: Max. 2mA @+3.0V, 2MHz
 - ✓ Stop Current1: Max. 1uA @+5.0V (All Clock OFF)
 - ✓ Stop Current2: Max. 450uA @+3.0V, 461kHz (Only WDT is on)
 - ✓ Stop Current3: Max. 5uA @+3.0V (Only ST is ON)
- ◆ **E.S.D. Protection up to 2,000 V**
- ◆ **Latch-up Protection Up to ± 200 mA**
- ◆ **Package**
 - ✓ 16-SOP

1.3 Applications

- ◆ Mobile Devices
- ◆ Multimedia
- ◆ Navigation Systems
- ◆ Home Appliance
- ◆ Other Electronic Devices

1.4 Product Family Guide

Product	Flash [Byte]	RAM [Byte]	Package	Programmable I/O	Other Peripherals
GC220	8K	128	20-TSSOP	18	3 Timer/Counters UART I2C WDT IAP ISP EJTAG LVD POR Precision Oscillator Stop Timer 16-channel 10-bit ADC 1-channel 10-bit PWM
GC221	4K	128	20-TSSOP 16-SOP 8-SOP	18 14 6	
GC222	2K	128	20-TSSOP	18	

2 Block Diagram

Figure shows the block diagram of **GC221-SO16IP**. Programs reside in the internal program memory (Embedded Flash Memory). Data are read from or written to data memory (SRAM) or special function registers (SFRs).

The internal registers of **GC221-SO16IP** are configured as part of the on-chip RAM: therefore each register has an address. This is reasonable for **GC221-SO16IP**, since it has so many registers.

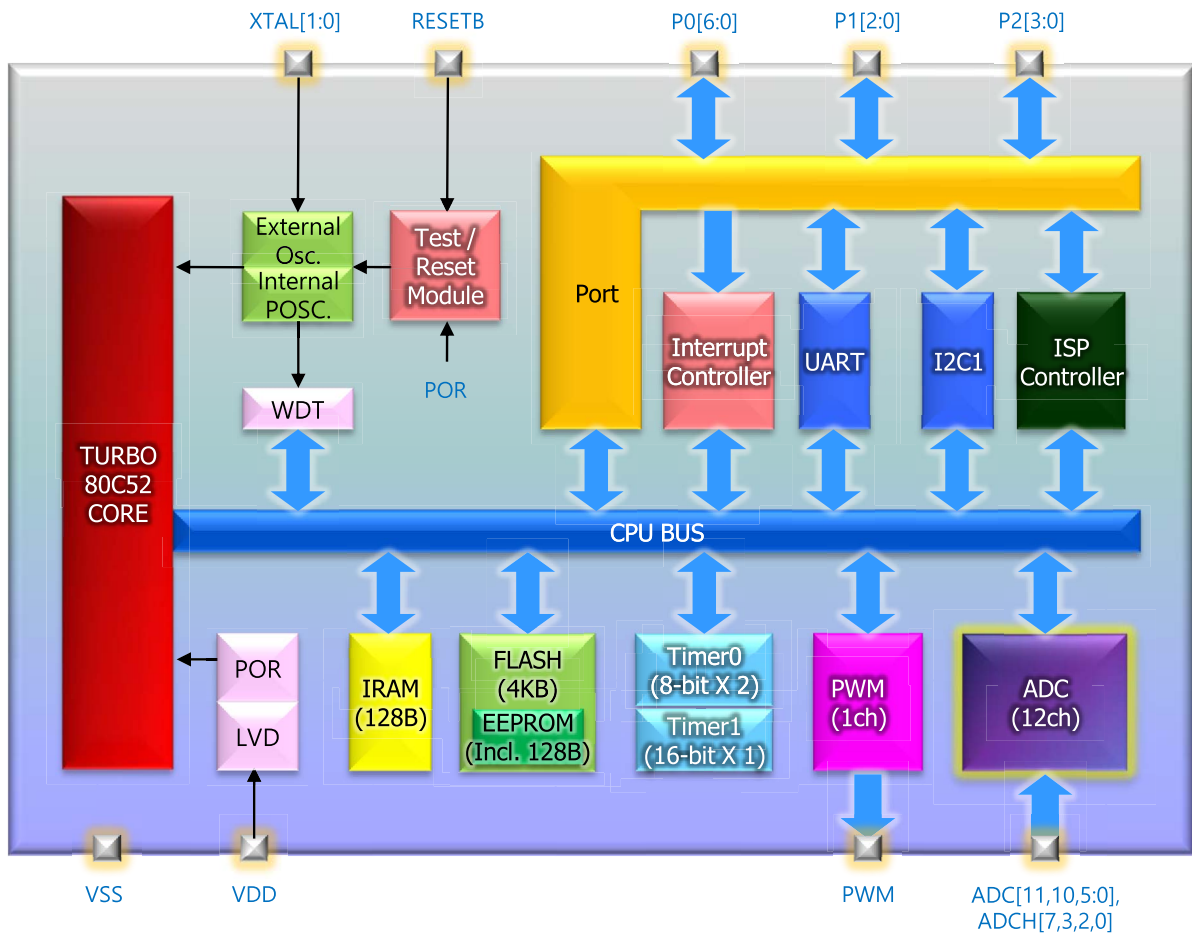

3 Pin Configuration

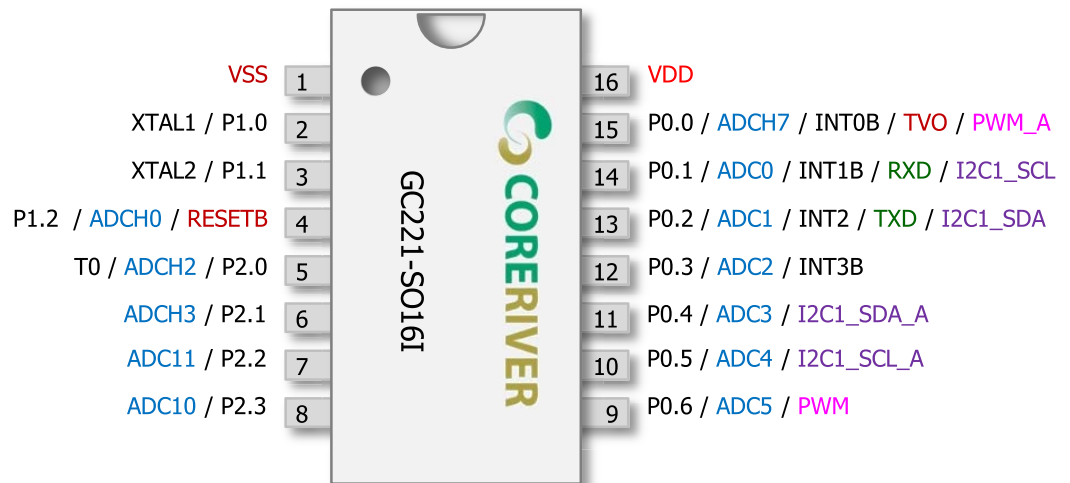

16-pin SOP Package Diagram

4 Pin Description

Pin No.	Name	Type	Description	Share Pins
1	VSS	GND		
2	XTAL1	I/O	Crystal Input	P1.0
3	XTAL2	I/O	Crystal Output	P1.1
4	RESETB	I/O	External Reset Input	P1.2 / ADCH0
5	P2.0	I/O	General I/O	T0 / ADCH2
6	P2.1	I/O	General I/O	ADCH3
7	P2.2	I/O	General I/O	ADC11
8	P2.3	I/O	General I/O	ADC10
9	P0.6	I/O	General I/O	ADC5 / PWM
10	P0.5	I/O	General I/O	ADC4 / I2C1_SCL_A
11	P0.4	I/O	General I/O	ADC3 / I2C1_SDA_A
12	P0.3	I/O	General I/O	ADC2 / INT3B
13	P0.2	I/O	General I/O	ADC1 / INT2 / TXD / I2C1_SDA
14	P0.1	I/O	General I/O	ADC0 / INT1B / RXD / I2C1_SCL
15	P0.0	I/O	General I/O	ADCH7 / INT0B / TVO / PWM_A
16	VDD	PWR		

5 Absolute Maximum Ratings

Item	Conditions	Range
Voltage on any pin relative to Ground	-	-0.5 V to ($V_{DDIO}+0.5V$)
Voltage in V_{DD} relative to Ground	-	-0.5V to 6.5V
Output Voltage	-	-0.5 V to ($V_{DDIO}+0.5V$)
Output Current High	One I/O pin active	-25mA
	All I/O pin active	-100mA
Output Current Low	One I/O pin active	+30mA
	All I/O pin active	+150mA
Storage Temperature	-	< 40°C
Soldering Temperature	-	260°C, 10 seconds within 5°C of actual peak temperature

6 DC Characteristics

* $T_A = -40^{\circ}\text{C} \sim +85^{\circ}\text{C}$, $V_{DD} = 2.2\text{V} \sim 5.5\text{V}$ unless otherwise specified

Parameter	Symbol	Pin	Conditions	Value			Unit
				Min.	Typ.	Max.	
Input Low Voltage	V_{IL1}	RESETB ,P0, P1, P2	$V_{DD} = 2.2\text{V} \sim 5.5\text{V}$	-0.5	-	$0.2V_{DD} - 0.1$	V
	V_{IL2}	XTAL1, XTAL2		0.5		$0.3V_{DD}$	
Input high Voltage	V_{IH1}	RESETB ,P0, P1, P2	$V_{DD} = 2.2\text{V} \sim 5.5\text{V}$	$0.2V_{DD} + 1.0$	-	$V_{DD} + 0.5$	V
	V_{IH2}	XTAL1, XTAL2		$0.7V_{DD}$	-	$V_{DD} + 0.5$	
Output Low Voltage	V_{OL}	All Pins	$I_{OL} = 17\text{mA} @V_{DD}=5\text{V}$ $I_{OL} = 7\text{mA} @V_{DD}=3\text{V}$ $I_{OL} = 4\text{mA} @V_{DD}=2.4\text{V}$	-	-	$0.3V_{DDIO}$	V
	V_{OL2}	P0[3:0] when high drive is enabled.	$I_{OL} = 50\text{mA} @V_{DD}=5\text{V}$ $I_{OL} = 20\text{mA} @V_{DD}=3\text{V}$ $I_{OL} = 12\text{mA} @V_{DD}=2.4\text{V}$	-	-	$0.3V_{DDIO}$	V
Output High Voltage	V_{OH}	All Pins	$I_{OH} = -18\text{mA} @V_{DD}=5\text{V}$ $I_{OH} = -6\text{mA} @V_{DD}=3\text{V}$ $I_{OH} = -3\text{mA} @V_{DD}=2.4\text{V}$	$0.7V_{DDIO}$	-	-	V
	V_{OH2}	P0[3:0] when high drive is enabled.	$I_{OH} = -26\text{mA} @V_{DD}=5\text{V}$ $I_{OH} = -8\text{mA} @V_{DD}=3\text{V}$ $I_{OH} = -4\text{mA} @V_{DD}=2.4\text{V}$	$0.7V_{DDIO}$	-	-	V
	V_{OHP}	ALL Pins (Pull-up Resistor Only)	$I_{OHP} = -49\mu\text{A} @V_{DD}=5\text{V}$ $I_{OHP} = -28\mu\text{A} @V_{DD}=3\text{V}$ $I_{OHP} = -22\mu\text{A} @V_{DD}=2.4\text{V}$	$0.7V_{DDIO}$	-	-	V
Input Leakage Current	I_{IL}	All Pins Except of XTAL1, XTAL2	$V_{IN} = V_{IH}$ or V_{IL}	-	-	± 1	μA
Pin Capacitance	C_{IO}	All Pins	$V_{DD} = 5\text{V}$	-	10	-	pF

7 AC Characteristics

* $T_A = -40\text{ }^{\circ}\text{C} \sim +85\text{ }^{\circ}\text{C}$ unless otherwise specified

Parameter	Symbol	Pin	Conditions	Value			Unit
				Min.	Typ.	Max.	
Operating Frequency	F_{SYS}	Internal Oscillator XTAL1, XTAL2	$V_{\text{DD}} = 5\text{V} \pm 10\%$	-	-	24	MHz
			$V_{\text{DD}} = 3\text{V} \pm 10\%$	-	-	12	
RESETB Input Width	t_{RST}	RESETB	$V_{\text{DD}} = 5\text{V} \pm 10\%$	20	-	-	F_{SYS}
			$V_{\text{DD}} = 3\text{V} \pm 10\%$	20	-	-	
External Interrupt Input Width	t_{INT}	External Interrupt	$V_{\text{DD}} = 5\text{V} \pm 10\%$	4	-	-	F_{SYS}
			$V_{\text{DD}} = 3\text{V} \pm 10\%$	4	-	-	

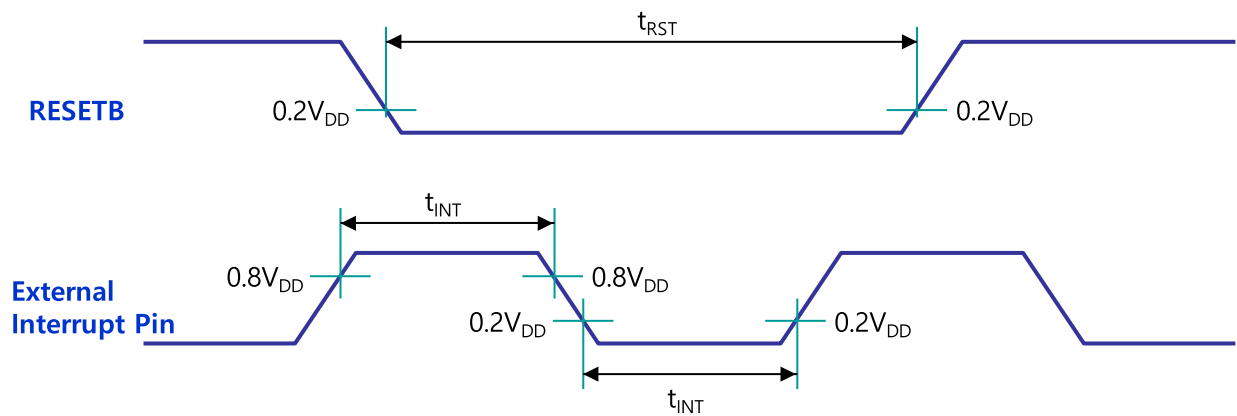

8 ADC Specifications

* $T_A = -40\text{ }^{\circ}\text{C} \sim +85\text{ }^{\circ}\text{C}$ unless otherwise specified

Parameter	Symbol	Conditions	Value			Unit	
			Min.	Typ.	Max.		
Supply Voltage	V_{DDADC}	$V_{DDADC} = V_{DD}$	2.4	-	5.5	V	
Input Voltage	V_{INADC}	-	V_{SS}	-	V_{DD}	V	
Resolution	RES_{ADC}	-	-	10	-	bit	
Operating Frequency	F_{ADC}	$V_{DD} = 4.5V \sim 5.5V$ $V_{DD} = 2.4V \sim 3.3V$	-	-	10 5	MHz	
Conversion Time	t_{ADC}	-	-	$96 / F_{ADC}$	-	s	
Overall Accuracy	OA_{ADC}	$V_{DD} = 5V, F_{ADC} = 10MHz$ $V_{DD} = 3V, F_{ADC} = 5MHz$	-	± 2	± 4	LSB	
Integral Nonlinearity	INL_{ADC}	$V_{DD} = 5V, F_{ADC} = 10MHz$ $V_{DD} = 3V, F_{ADC} = 5MHz$	-	± 2	± 4	LSB	
Differential Nonlinearity	DNL_{ADC}	$V_{DD} = 5V, F_{ADC} = 10MHz$ $V_{DD} = 3V, F_{ADC} = 5MHz$	-	± 0.5	± 1	LSB	
Zero Input Error	ZIE_{ADC}	$V_{DD} = 5V, F_{ADC} = 10MHz$ $V_{DD} = 3V, F_{ADC} = 5MHz$	-	± 2	± 4	LSB	
Full Scale Error	FSE_{ADC}	$V_{DD} = 5V, F_{ADC} = 10MHz$ $V_{DD} = 3V, F_{ADC} = 5MHz$	-	± 2	± 4	LSB	
Analog Input Capacitance	C_{INADC}	-	-	10	15	pF	
ADC Current	Active	I_{ADC}	$V_{DD} = 5V, F_{ADC} = 10MHz$	-	1	2	mA
			$V_{DD} = 3V, F_{ADC} = 5MHz$	-	0.3	0.6	
	Power-down	$V_{DD} = 5V$	-	-	100	nA	

9 I2C Timing Characteristics

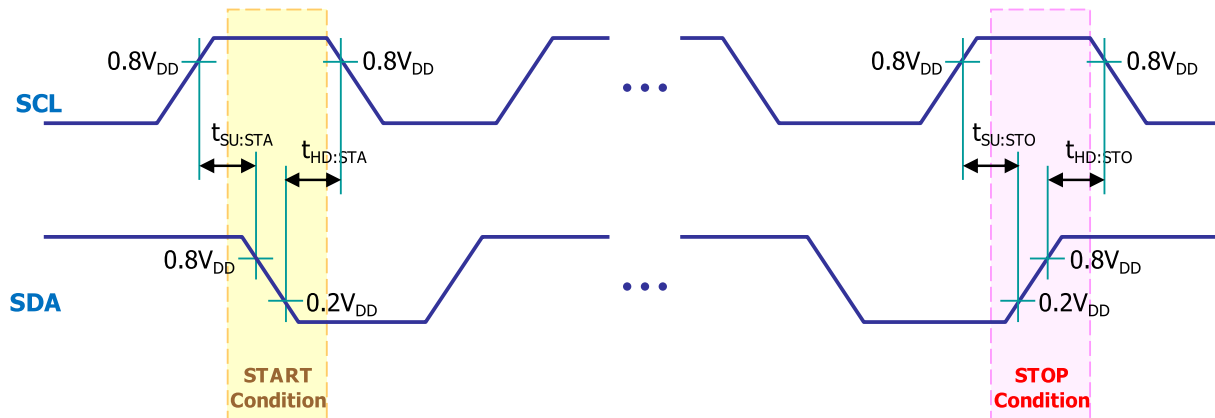

Symbol	Characteristics		Min. [ns]	Max. [ns]	Conditions
$t_{SU:STA}$	START Condition Setup Time	100kHz Mode	4,700	-	Only relevant for repeated START condition
		400kHz Mode	600	-	
$t_{HD:STA}$	START Condition Hold Time	100kHz Mode	4,700	-	After this period, the first clock pulse is generated
		400kHz Mode	600	-	
$t_{SU:STO}$	STOP Condition Setup Time	100kHz Mode	4,700	-	
		400kHz Mode	600	-	
$t_{HD:STO}$	STOP Condition Hold Time	100kHz Mode	4,700	-	
		400kHz Mode	600	-	

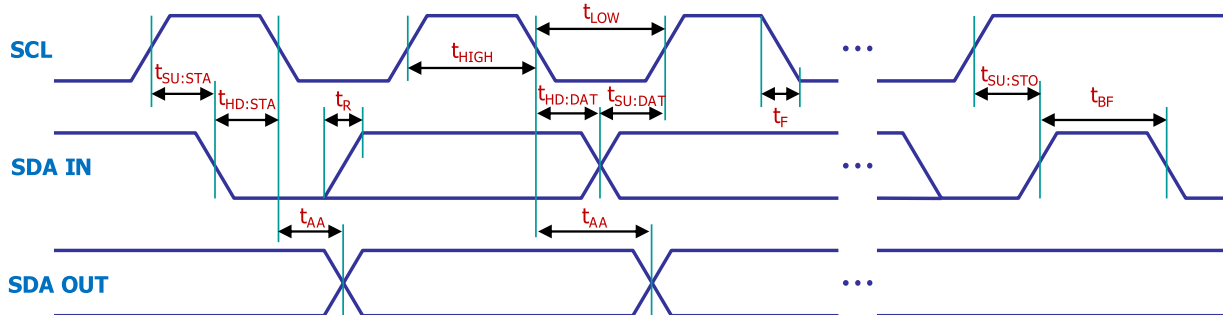

Symbol	Characteristics	Min. [ns]	Max. [ns]	Conditions	
t_{HIGH}	Clock High Time	100kHz Mode	4,000	-	Minimum Frequency : 1MHz
		400kHz Mode	600	-	Minimum Frequency : 5MHz
t_{LOW}	Clock Low Time	100kHz Mode	4,700	-	Minimum Frequency : 1MHz
		400kHz Mode	1,300	-	Minimum Frequency : 5MHz
$t_{SU:DAT}$	Data Input Setup Time	100kHz Mode	250	-	
		400kHz Mode	100	-	
$t_{HD:DAT}$	Data Input Hold Time	100kHz Mode	0	-	
		400kHz Mode	0	900	
t_{AA}	Data Valid from Clock	100kHz Mode	-	3,500	
		400kHz Mode	-	-	
t_{BF}	BUS Free Time	100kHz Mode	4,700	-	
		400kHz Mode	1,300	-	
t_R	SDA & SCL Rising Time	100kHz Mode	-	1,000	The Range of Cb is from 10pF to 400pF
		400kHz Mode	$2.0 + 0.1C_b$	300	
t_F	SDA & SCL Falling Time	100kHz Mode	-	300	The Range of Cb is from 10pF to 400pF
		400kHz Mode	$2.0 + 0.1C_b$	300	

10 16-pin SOP Package Dimension

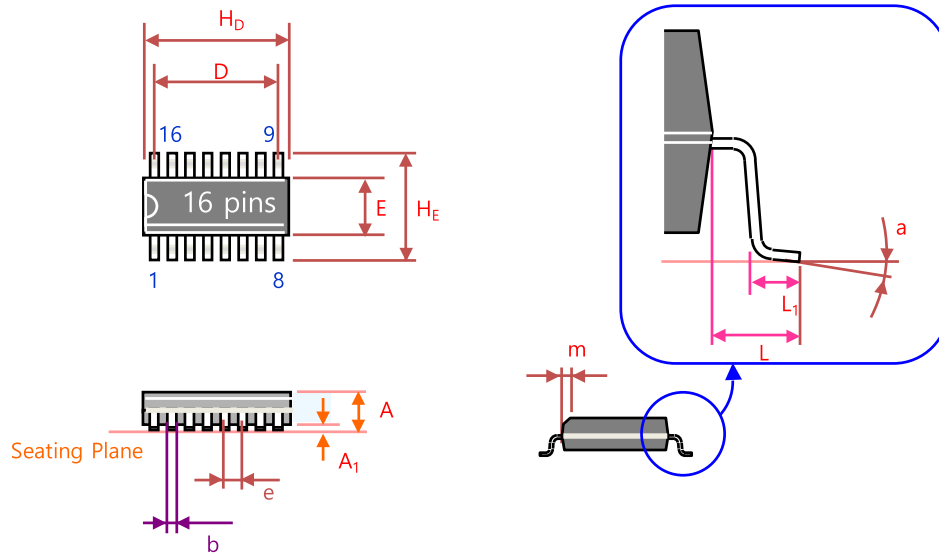

Symbol	Dimension in Inches			Dimension in mm		
	Min.	Nom.	Max.	Min.	Nom.	Max.
A	0.093	0.099	0.104	2.35	2.45	2.65
A_1	0.004	0.008	0.012	0.10	0.20	0.30
b	0.014	0.016	0.019	0.35	0.42	0.49
D	-	.350	-	-	8.89	-
E	0.150	0.153	0.157	3.80	3.90	4.00
H_D	0.398	0.405	0.413	10.10	10.29	10.50
H_E	0.234	0.239	0.244	5.95	6.07	6.20
L	0.038	0.043	0.048	0.97	1.08	1.2
L_1	0.022	0.027	0.032	0.58	0.70	0.82
a	0 [°]	-	8 [°]	0 [°]	-	8 [°]
e	0.050 BSC			1.27 BSC		
m	0.010	0.015	0.020	0.25	0.37	0.50

Notes:

1. Dimension D & E include mold mismatch and are determined at the mold parting line.
2. General appearance spec. should be based on final visual inspection spec.