

ResetCore Family

CMOS Based Reset IC

Preliminary Specification Sheet

- ◆ *CORERIVER Semiconductor reserves the right to make corrections, modifications, enhancements, improvements, and other changes to its products and services at any time.*
- ◆ *To discontinue any product or service, CORERIVER should inform customers of that before 3 months through its homepage.*
- ◆ *Customers should obtain the latest relevant information before placing orders and should verify that such information is current and complete.*
- ◆ *The CORERIVER Semiconductor products listed in this document are intended for usage in general electronics applications. These CORERIVER Semiconductor products are neither intended nor warranted for usage in equipment that requires extraordinarily high quality and/or reliability or a malfunction or failure of which may cause loss of human life or bodily injury.*

Copyright CORERIVER Semiconductor Co., Ltd. 2012

All Rights Reserved

1 ResetCore Overview

1.1 General Description

The **ResetCore** family is usable for the CPU system of all types and wired logic system.

It has the function of assertion a reset if the power supply drops below a designated reset threshold level.

Several different reset threshold levels are available.

This **ResetCore** family has an active low output.

The **ResetCore** family operates over the extended -20°C to $+80^{\circ}\text{C}$ temperature range, and is available in SOT-23 package.

1.2 Features

- ◆ Precision voltage monitor for 1.70V ~ 4.50V
- ◆ No external components required
- ◆ Low Power Consumption
- ◆ Low Temperature Coefficient
- ◆ Built-in Voltage Reference
- ◆ Comparator Hysteresis
- ◆ SOT-23 package are available

1.3 Applications

- ◆ Portable equipment
- ◆ Intelligent instruments
- ◆ Critical microprocessor power monitoring
- ◆ Embedded controllers
- ◆ Control Circuit of Battery-Backed Memory Units.
- ◆ Measure Against Erroneous Operations at Power Supply ON-OFF Time.
- ◆ Measure Against System Runaway at Instantaneous Break of Power Supply etc.
- ◆ Resetting Function for the CPU-Mounted Equipment, such as personal Computers, Printers, VTRs and so forth.

1.4 Product Family Guide

Product	Value			Unit
	Min.	Typ.	Max.	
ResetCore170	1.6	1.7	1.8	V
ResetCore190	1.8	1.9	2.0	
ResetCore210	2.0	2.1	2.2	
ResetCore230	2.2	2.3	2.4	
ResetCore250	2.4	2.5	2.6	
ResetCore270	2.6	2.7	2.8	
ResetCore290	2.8	2.9	3.0	
ResetCore310	3.0	3.1	3.2	
ResetCore330	3.2	3.3	3.4	
ResetCore350	3.4	3.5	3.6	
ResetCore370	3.6	3.7	3.8	
ResetCore390	3.8	3.9	4.0	
ResetCore410	4.0	4.1	4.2	
ResetCore430	4.2	4.3	4.4	
ResetCore450	4.4	4.5	4.6	

2 Pin Configuration

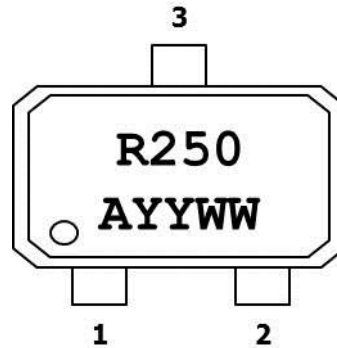

SOT-23 Package Diagram

Pin Number	Pin Name	Type	Description
1	V _{DD}	V _{DD}	Power Supply
2	OUT	O	RESETB goes low if V _{DD} falls below the reset threshold.
3	GND	GND	Ground

3 EQUIVALENT CIRCUIT

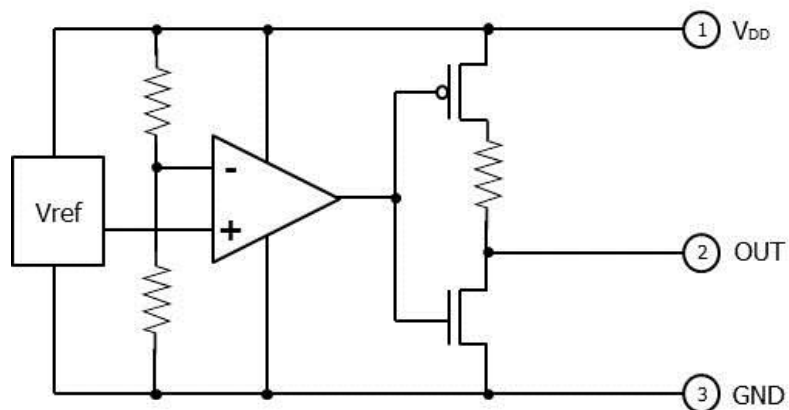

4 Absolute Maximum Ratings

Item	Symbol	Range
Supply Voltage	V_{DD}	-0.5V to 5.5V
Output current, RESETB	I_{RESETB}	12mA
Operation temperature	T_{opr}	-20°C to +80°C
Storage Temperature	T_{stg}	-55°C to +125°C
Soldering Temperature	T_{sod}	260°C, 10 seconds within 5°C of actual peak temperature

5 Timing Diagram

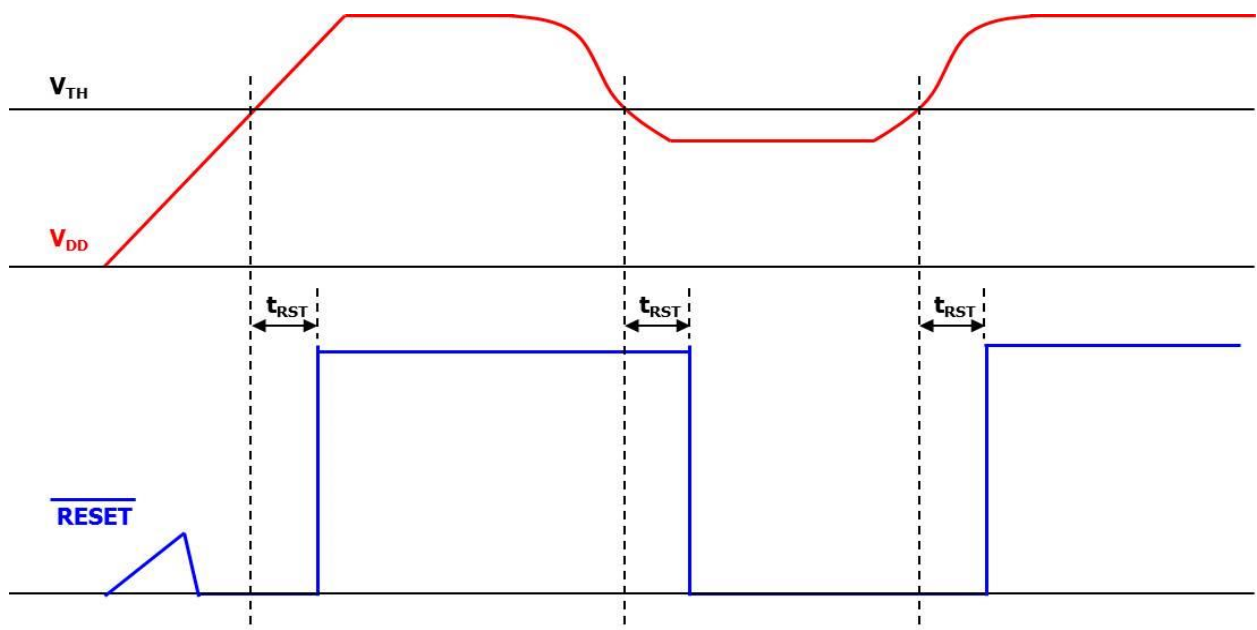

6 DC Characteristics

* $T_A = -20^{\circ}\text{C} \sim +80^{\circ}\text{C}$, $V_{DD} = +1.6\text{V} \sim +5.5\text{V}$ unless otherwise specified

Parameter	Symbol	Conditions	Value			Unit
			Min	Typ	Max	
Operating Voltage	V_{DD}	$T_A = -20^{\circ}\text{C} \sim +80^{\circ}\text{C}$	1.6	-	5.5	V
Supply Current	I_{DD}	$V_{DD} = 5.25\text{V}$	-	30	50	μA
Reset Voltage Threshold	V_{TH}	ResetCore170	1.6	1.7	1.8	V
		ResetCore190	1.8	1.9	2.0	
		ResetCore210	2.0	2.1	2.2	
		ResetCore230	2.2	2.3	2.4	
		ResetCore250	2.4	2.5	2.6	
		ResetCore270	2.6	2.7	2.8	
		ResetCore290	2.8	2.9	3.0	
		ResetCore310	3.0	3.1	3.2	
		ResetCore330	3.2	3.3	3.4	
		ResetCore350	3.4	3.5	3.6	
		ResetCore370	3.6	3.7	3.8	
		ResetCore390	3.8	3.9	4.0	
		ResetCore410	4.0	4.1	4.2	
		ResetCore430	4.2	4.3	4.4	
ResetCore450	4.4	4.5	4.6			
Reset Timeout Period	t_{RST}		10	-	-	μS
RESET Output Voltage, High	V_{OH}		$0.7 V_{DD}$	-	-	V
RESET Output Voltage, Low	V_{OL}		-	-	$0.3 V_{DD}$	V

7 Package Dimension

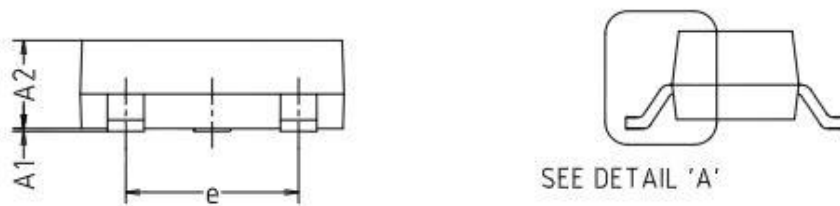
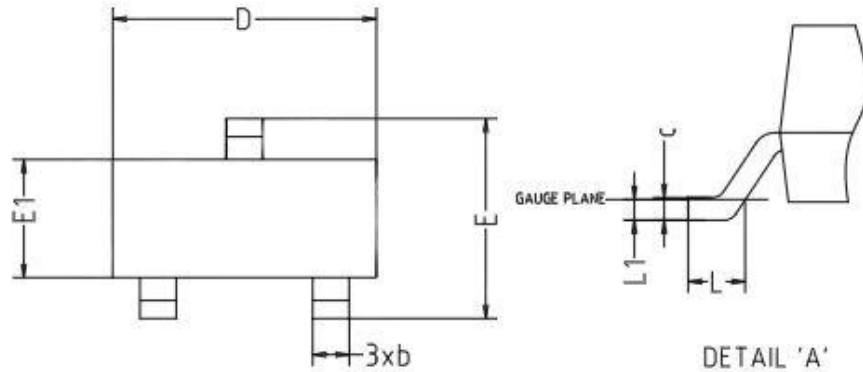

Symbol	Dimensions [mm]		
	Min.	Nom.	Max.
A ₁	0.00	-	0.10
A ₂	0.82	-	1.02
b	0.39	0.42	0.45
c	0.09	0.12	0.15
D	2.80	2.90	3.00
E	2.20	2.40	2.60
E ₁	1.20	1.30	1.40
e	1.90BSC		
L	0.20	-	-
L ₁	0.12BSC		

Notes:

- DIMENSIONS IN MILLIMETERS.**
- DIMENSION D AND E1 DO NOT INCLUDE MOLD FLASH. PROTRUSIONS OR GATE BURRS, MOLD FLASH, PROTRUSIONS OR GATE BURRS SHALL NOT EXCEED 0.15mm PER END.**
- DIMENSION D AND E1 ARE DETERMINED AT THE OUTMOST EXTREMES OF THE PLASTIC BODY EXCLUSIVE OF MOLD FLASH, TIE BAR BURRS, GATE BURRS AND INTERLEAD FLASH, BUT INCLUDING ANY MISMATCH BETWEEN THE TOP AND BOTTOM OF THE PLASTIC BODY.**