



RingCore220 Family: Optimized Driver IC For LRA/ERM

Ver. 1.0

February 2012

**Copyright CORERIVER Semiconductor Co., Ltd. 2012
All Rights Reserved**

- ◆ *CORERIVER Semiconductor reserves the right to make corrections, modifications, enhancements, improvements, and other changes to its products and services at any time.*
- ◆ *To discontinue any product or service, CORERIVER should inform customers of that before 3 months through its homepage.*
- ◆ *Customers should obtain the latest relevant information before placing orders and should verify that such information is current and complete.*
- ◆ *The CORERIVER Semiconductor products listed in this document are intended for usage in general electronics applications. These CORERIVER Semiconductor products are neither intended nor warranted for usage in equipment that requires extraordinarily high quality and/or reliability or a malfunction or failure of which may cause loss of human life or bodily injury.*

1 Product Overviews

RingCore220 is a motor driver IC to drive LRA(Linear Resonant Actuator) and ERM(Eccentric Rotating Mass). It can adjust the vibration amplitude and the Haptic effect with an external PWM (Pulse Width Modulation) signal. So it can generate various feelings of touch. Additionally, RingCore220 contains the frequency tuning function, which searches the driving frequency to vibrate an LRA maximally and to stop it most quickly. A normal driver IC drives an LRA with a specific frequency that is determined initially and maintained. However, mechanical characteristics and frequency characteristics change because of aging and external shocks. These kinds of changes reduce the vibration amplitude and the Haptic effect.

RingCore220 solves these kinds of progressive failures without replacement of a driver IC through the frequency tuning. A RingCore220 application tunes the driving PWM frequency again to the maximum LRA vibration frequency deviated due to change of mechanical characteristics. As a result, no additional LRA driver IC is needed to maintain the vibration amplitude and the Haptic effect

2 Features

- ◆ Support Motor Driving Frequency Tuning : Maximum Vibration Frequency Search Function
- ◆ Support two actuators types : LRA / ERM
- ◆ Wide output frequency capability : 80Hz < Resonant Frequency < 390Hz
- ◆ Output swing : $V_{SS}+100mV \sim V_{DD}+100mV$ (Almost Rail-to-Rail)
- ◆ Fast wake-up time : output available 1ms after EN is active
- ◆ Singled-PWM input : 10KHz < PWM < 50KHz (LRA / ERM)
- ◆ Support low-impedance actuator down to 7.5 Ω
- ◆ Built-in weak pull down on all inputs
- ◆ Settable filter in GAIN using external capacitor
- ◆ DC gain settable in GAIN using an external resistor
- ◆ Over-current limitation
- ◆ Standby Current : Max. 1 μ A
- ◆ Output offset : Typical 50mV (Maximum 200mV)
- ◆ Package type : 2.0mmX2.0mm MLF

3 Pin Configurations

The RingCore220 family supports the package, e.g. ML10IP. The detailed pin configuration is shown in Figure 3-1.

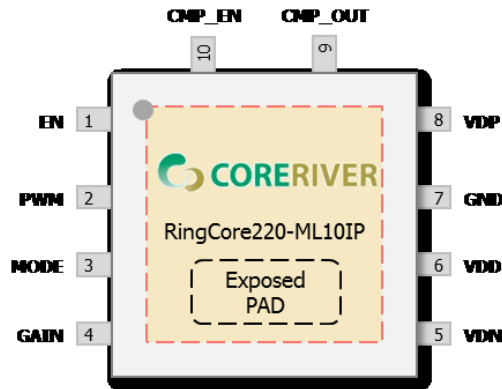

Figure 3-1 Pin Configurations

4 Pin Descriptions

Symbol	Direction	Pin Name	Description
1	I	EN	Enable the Driver IC
2	I	PWM	PWM Input Control Vibration Power (1% to 99%) - 99% : Maximum Vibration - 50% : No Vibration - 1% : Maximum Breaking (when PWM sets 99% for Vibration)
3	I	MODE	High : LRA Mode Low : ERM Mode
4	I	GAIN	Resistor to VDN sets DC Gain Capacitor to VDN sets Output Filter Frequency
5	O	VDN	Actuator Connector : Negative
6	Power	VDD	Power Supply
7	Power	GND	Power Ground
8	O	VDP	Actuator Connector : Positive
9	O	CMP_OUT	Pulse Output for Frequency Tuning
10	O	CMP_EN	Frequency Tuning Enable

5 Typical Application

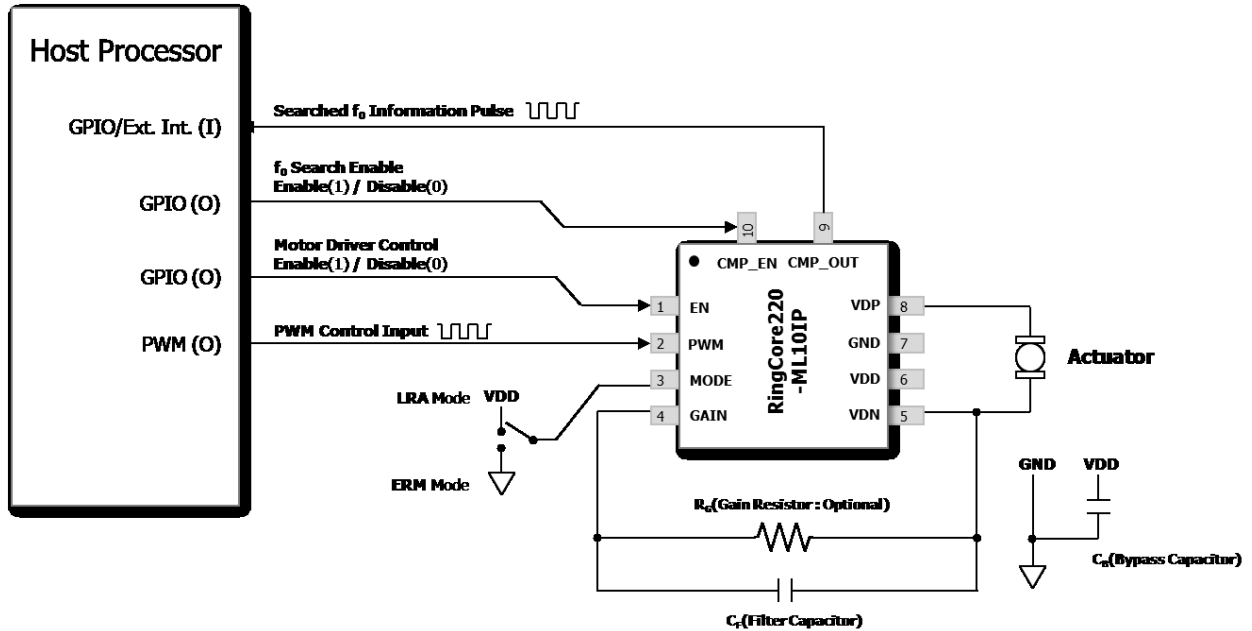

Figure 5-1 Typical Application Circuit

- ◆ V_{DD} power of RingCore220 should be supplied by regulated power
- ◆ EN pin of RingCore220 should be controlled by GPIO of Host Processor to disable RingCore220
- ◆ The R_G (Gain Resistor) is used to set the output(VDP, VDN) voltage gain.
 - The output gain by the R_G optionally. (default output gain is '1' without R_G)
 - If R_G is 60 k Ω , output gain is half of default value (0.5).
 - If V_{DD} is higher than required, adjusting the value of R_G to reduce output voltage.
 - The value of R_G is based on V_{DD} and motor's operating ratings.
 - Output voltage only can be reduced by R_G .
- ◆ The C_F (Filter Capacitor) is used to regulate output high frequency harmonics.
 - Increasing the value of C_F \rightarrow Removing high frequency harmonics of the PWM on the outputs.
- ◆ In LRA mode, PWM frequency is same to 128 times of the LRA's resonant frequency.
- ◆ Don't need any protection component on VDP, VDN

5.1 How to use reference table

- Define input V_{DD} voltage and Search actuator's operating ratings (V_{rms})
- Tracking down output voltage(VDP, VDN) of RingCore220 as you want to use
- Find the R_G on left side
- For example : V_{DD} is 3.0V, LRA's operating ratings (Input V_{rms}) is $2.0V_{rms}$ → R_G value is 180 k Ω

Table 5-1 R_G Reference Table

V_{DD} R_G (ohm)	2.5V	2.6V	2.7V	2.8V	2.9V	3.0V	3.1V	3.2V	3.3V	3.4V	3.5V	3.6V	3.7V
68K	1.17	1.22	1.27	1.31	1.36	1.40	1.45	1.49	1.54	1.59	1.63	1.68	1.73
75K	1.22	1.27	1.32	1.36	1.41	1.46	1.51	1.56	1.61	1.66	1.71	1.76	1.81
82K	1.27	1.32	1.37	1.42	1.47	1.52	1.57	1.62	1.67	1.73	1.78	1.83	1.88
91K	1.33	1.38	1.43	1.49	1.54	1.59	1.65	1.70	1.76	1.81	1.86	1.92	1.98
100K	1.36	1.42	1.47	1.53	1.58	1.64	1.69	1.75	1.81	1.86	1.92	1.98	2.03
110K	1.41	1.47	1.52	1.58	1.64	1.70	1.76	1.81	1.87	1.93	1.99	2.05	2.10
120K	1.45	1.51	1.56	1.62	1.68	1.74	1.80	1.86	1.92	1.98	2.04	2.10	2.16
130K	1.49	1.55	1.61	1.67	1.73	1.79	1.86	1.92	1.98	2.05	2.11	2.17	2.23
150K	1.55	1.61	1.68	1.74	1.80	1.87	1.93	2.00	2.07	2.13	2.20	2.26	2.33
160K	1.58	1.64	1.71	1.77	1.84	1.91	1.97	2.04	2.11	2.17	2.24	2.30	2.36
180K	1.64	1.70	1.77	1.84	1.91	1.98	2.05	2.12	2.18	2.25	2.31	2.38	2.44
200K	1.67	1.74	1.81	1.88	1.95	2.02	2.09	2.16	2.23	2.29	2.36	2.42	2.49
220K	1.71	1.78	1.85	1.92	1.99	2.07	2.14	2.21	2.27	2.34	2.41	2.47	2.54
240K	1.74	1.81	1.88	1.96	2.03	2.10	2.18	2.24	2.31	2.38	2.45	2.52	2.58
270K	1.78	1.85	1.93	2.00	2.08	2.15	2.23	2.29	2.36	2.43	2.50	2.57	2.64
300K	1.81	1.88	1.96	2.04	2.11	2.19	2.26	2.33	2.40	2.47	2.54	2.62	2.69
330K	1.82	1.90	1.98	2.05	2.13	2.21	2.28	2.35	2.42	2.49	2.56	2.64	2.71
360K	1.86	1.94	2.02	2.10	2.17	2.25	2.32	2.39	2.46	2.54	2.61	2.69	2.76
390K	1.89	1.97	2.05	2.13	2.21	2.28	2.35	2.43	2.50	2.58	2.65	2.73	2.81
430K	1.90	1.98	2.07	2.15	2.22	2.30	2.37	2.44	2.52	2.60	2.67	2.75	2.83
470K	1.93	2.01	2.09	2.17	2.24	2.32	2.39	2.49	2.55	2.62	2.70	2.78	2.86
510K	1.94	2.02	2.11	2.19	2.26	2.34	2.41	2.49	2.57	2.65	2.73	2.81	2.89

※ R_G value is estimated value only, so must adjust by each Application.

If V_{DD} don't exceed actuator's input ratings, R_G can be removed.

5.2 How to tune the LRA driving frequency

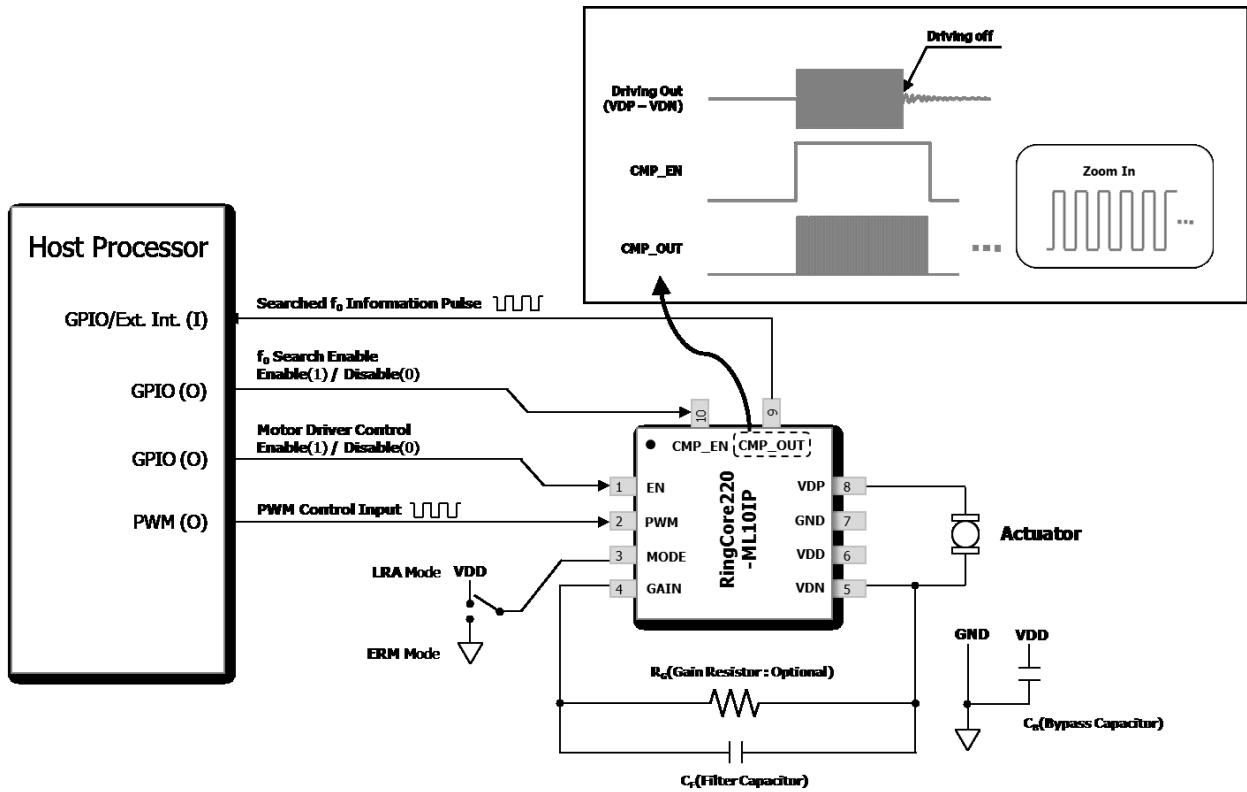

Figure 5-2 Frequency Tuning Scheme

- Main Processor can tune motor driving frequency by analyzing out pulse from CMP_OUT port
 - a) LRA Driving On (Port Control → EN '1', CMP_EN '1')
 - b) LRA Driving Off (Port Control → EN '0', CMP_EN '1')
 - c) Measure specific period of CMP_OUT pulse
 - d) Calculate frequency of measured pulse
 - e) Renewal LRA driving frequency calculated frequency

6 Absolute Maximum Ratings

Table 6-1 Absolute Maximum Ratings

Items	Conditions	Ranges
Voltage on Any Pin Relative to Ground	-	-0.5 to ($V_{DD} + 0.5V$)
Voltage in V_{DD} Relative to Ground	-	-0.5V to 3.7V
Output Voltage	-	-0.5V to ($V_{DD} + 0.5V$)
Output Current High	One I/O Pin Active	-25mA
	All I/O Pins Active	- 100mA
Output Current Low	One I/O Pin Active	+ 30mA
	All I/O Pins Active	+ 150mA
Storage Temperature	-	-65°C to +150°C
Soldering Temperature	-	260°C for 10 seconds

7 DC Characteristics

Table 7-1 DC Characteristics

Parameter	Symbol	Pin	Conditions	Value			Unit
				Min.	Typ.	Max.	
Input Low Voltage	VIL	EN, PWM	$V_{DD} = +2.7$ to $+3.7V$	-	-	0.4	V
Input High Voltage	VIH	EN, PWM	$V_{DD} = +2.7$ to $+3.7V$	1.0	-	-	V
Output Low Voltage	OL	MP_OUT	$I_{OL} = +13mA$ @ $V_{DD} = +3V$	-	-	$0.3V_{DD}$	V
Output High Voltage	OH	MP_OUT	$I_{OH} = -13mA$ @ $V_{DD} = +3V$	$0.7V_{DD}$	-	-	V
Quiescent Power Supply Current	IDDQ	VDP, VDN	VPWM = 50% Duty, $R_L = 30\Omega$	8	13	17	mA
Output Offset Voltage	OS	VDP, VDN	VPWM = 50% Duty, $R_L = 30\Omega$	-200	50	200	mV
Output Current	OUT	VDP, VDN	VOH, VOL $\leq 200mV$	-	200	-	mA
Input Leakage Current	IIL	All Pins	$V_{IN} = V_{IH}$ or V_{IL} ($V_{EN} = 0$)	-	-	± 1	μA
Pin Capacitance	CIO	All Pins	$V_{DD} = +3.7V$	-	10	-	pF

※ $T_A = -40^\circ C$ to $85^\circ C$, $V_{DD} = +2.7V$ to $+3.7V$ unless Otherwise Specified.

