



## Spec. Draft of SecurityCore5.0

### System Copy Protection

V2.9

2014. 06

- ◆ CORERIVER Semiconductor reserves the right to make corrections, modifications, enhancements, improvements, and other changes to its products and services at any time.
- ◆ CORERIVER shall give customers at least a three month advance notice of intended discontinuation of a product or a service through its homepage.
- ◆ Customers should obtain the latest relevant information before placing orders and should verify that such information is current and complete.
- ◆ The CORERIVER products listed in this document are intended for usage in general electronics applications. These CORERIVER products are neither intended nor warranted for usage in equipment that requires extraordinarily high quality and/or reliability or a malfunction or failure of which may cause loss of human life or bodily injury.

# Contents

1. What's Copy Protection?
  - ✓ Case 1 : without SecurityCore
  - ✓ Case 2 : with SecurityCore
2. Production Overview
3. Features
4. Block Diagram
5. Pin Configurations
  - ✓ SecurityCore5.0
6. Pin Descriptions
7. Application Circuit
8. Strong Point of CORERIVER SECURITYCORE
9. I2C Interface
10. I2C Speed
11. How to Support Library
12. Absolute Maximum Ratings
13. DC Characteristics
14. AC Characteristics
15. Package Dimensions

# 1. What's Copy Protection?

*Confidential*

## ◆ Without SecurityCore

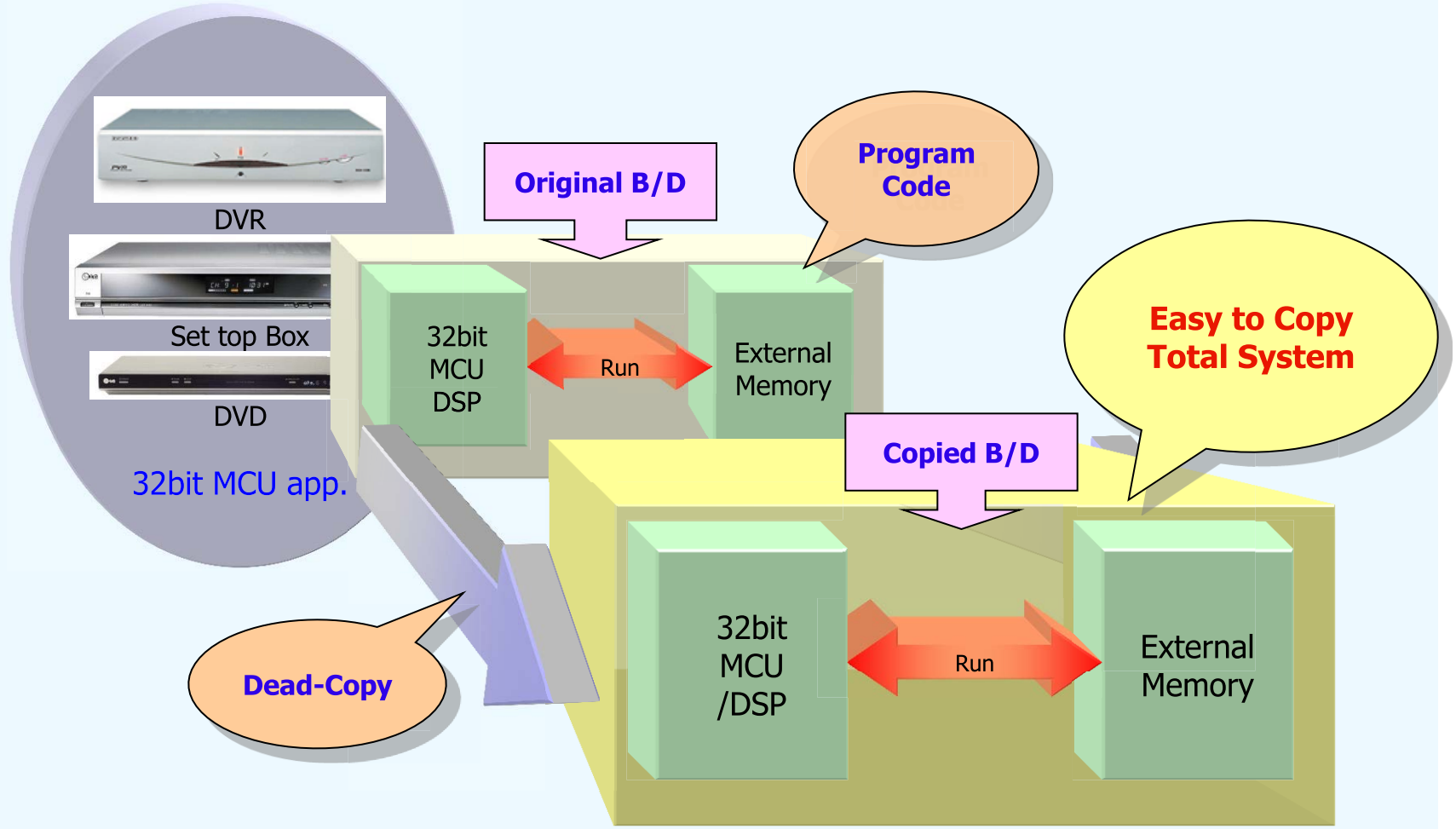

# 1. What's Copy Protection? (Cont'd)

*Confidential*

## ◆ With SecurityCore

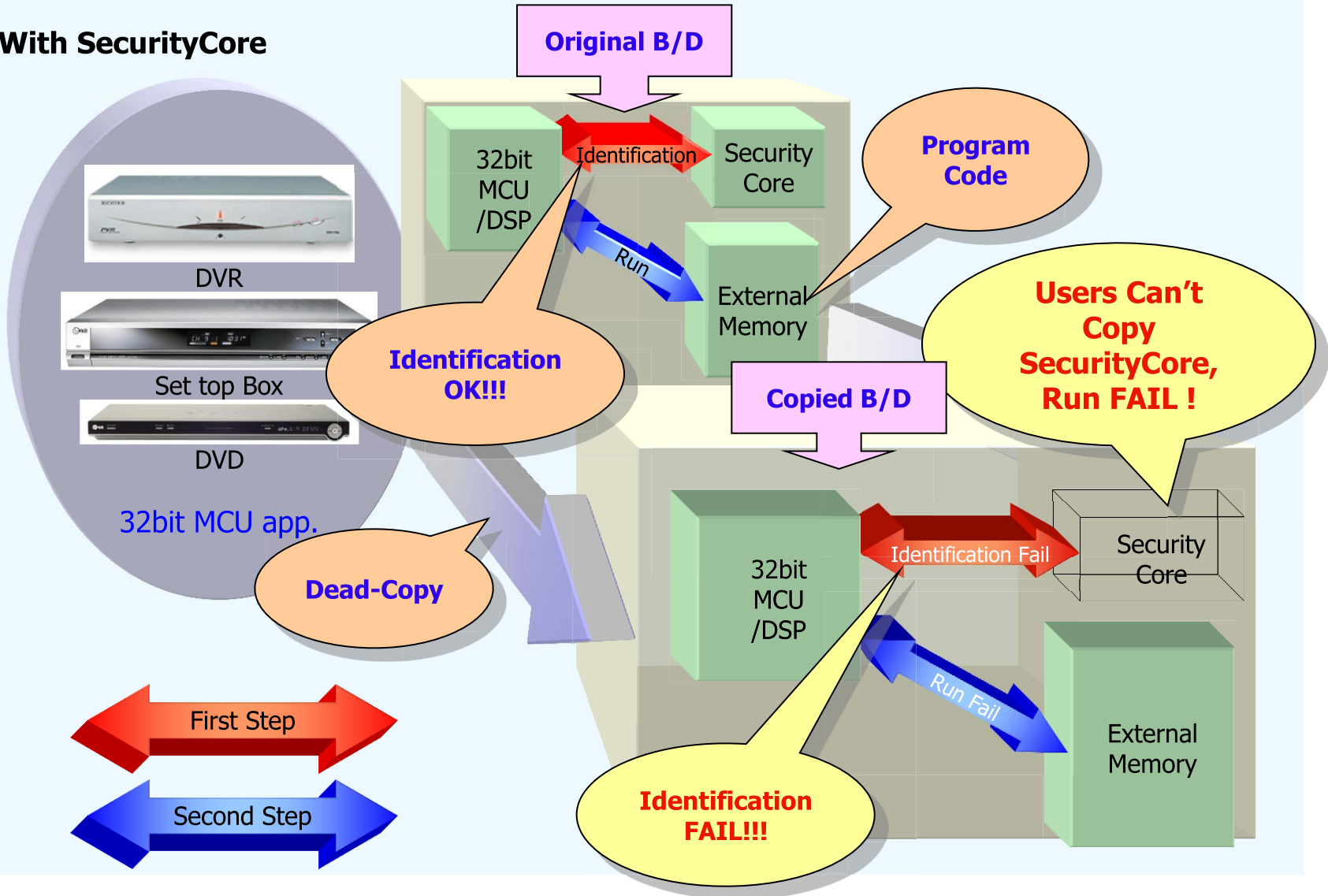

## 2. Product Overview

- ◆ The solution of System Copy Protection.
- ◆ Support a unique identification number
- ◆ Inventory Tracking
- ◆ Customizing Unique Algorithm

## 3. Features

### ◆ Security

- ✓ Support Random Number Generation
- ✓ Encoder Read Protect
- ✓ Unique Algorithm : 96 Bit Encryption
- ✓ Provide Unique SEED Key

### ◆ Operation

- ✓ 2.2 ~ 5.5 Volts Operation
- ✓ Enhanced Power noise immunity
- ✓ -40 °C to 85 °C operating temperature
- ✓ Active current : Max. 2mA @3.3V, 2MHz
- ✓ Stop current : Max. 1uA (All Clock Off)
- ✓ Program Interface : I2C Interface
- ✓ E.S.D. protection up to 2,000V
- ✓ Package : 8-SOIC

# 4. Block Diagram

*Confidential*

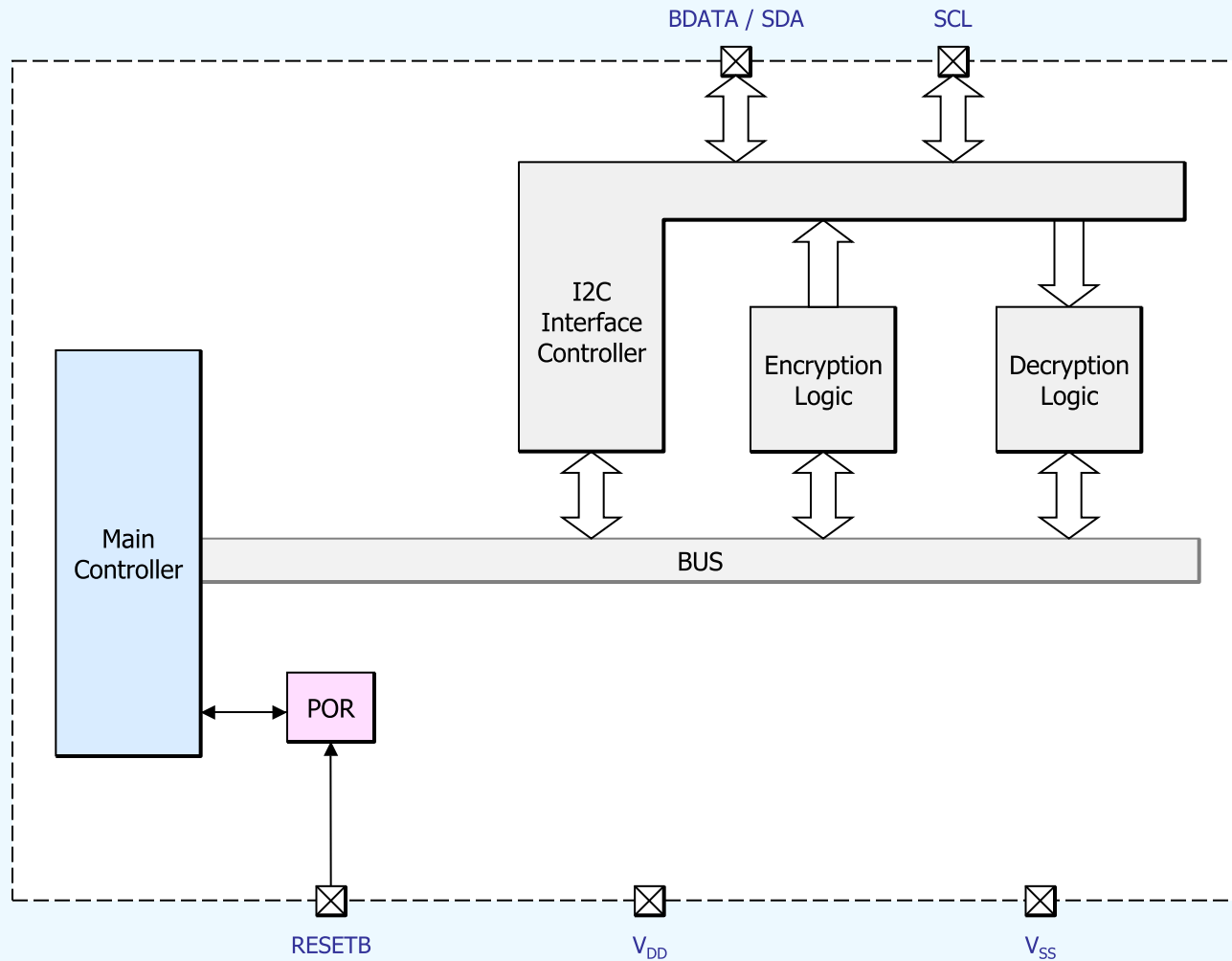

# 5. Pin Configurations

*Confidential*

## ◆ SecurityCore5.0

✓ I2C interface

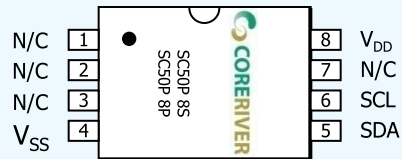

[ 8-SOIC ]



## 6. Pin Descriptions

### ◆ SecurityCore5.0

Symbol	Direction	Description	Share Pins
V <sub>DD</sub>	Input	Voltage Power Source	-
V <sub>SS</sub>	Input	Voltage Power Ground	-
SDA	Input/Output	▪ Data I/O	-
SCL	Input/Output	▪ Clock I/O	-
OTHERS		▪ Data I/O	-

# 7. Application Circuit

◆ I2C Interface

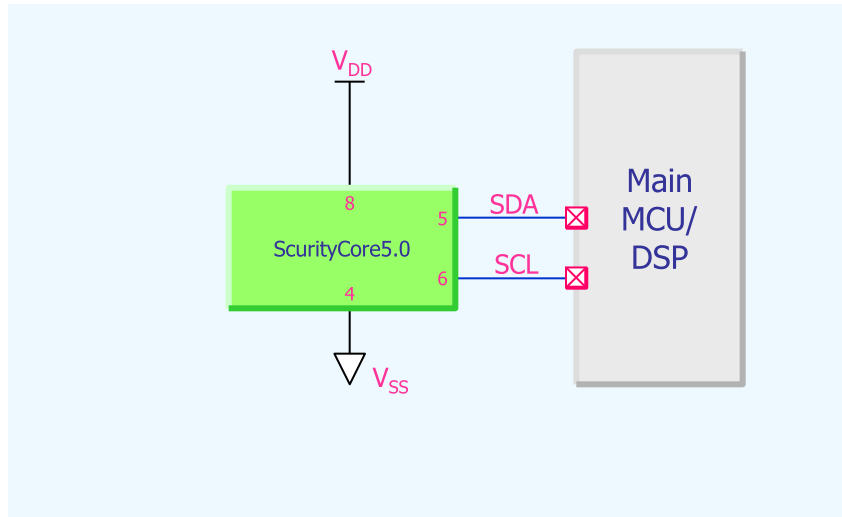

## 8. Strong Point of CORERIVER SC50 (1/2)

- ◆ SC50 stores a security algorithm as extremely small electric charges.

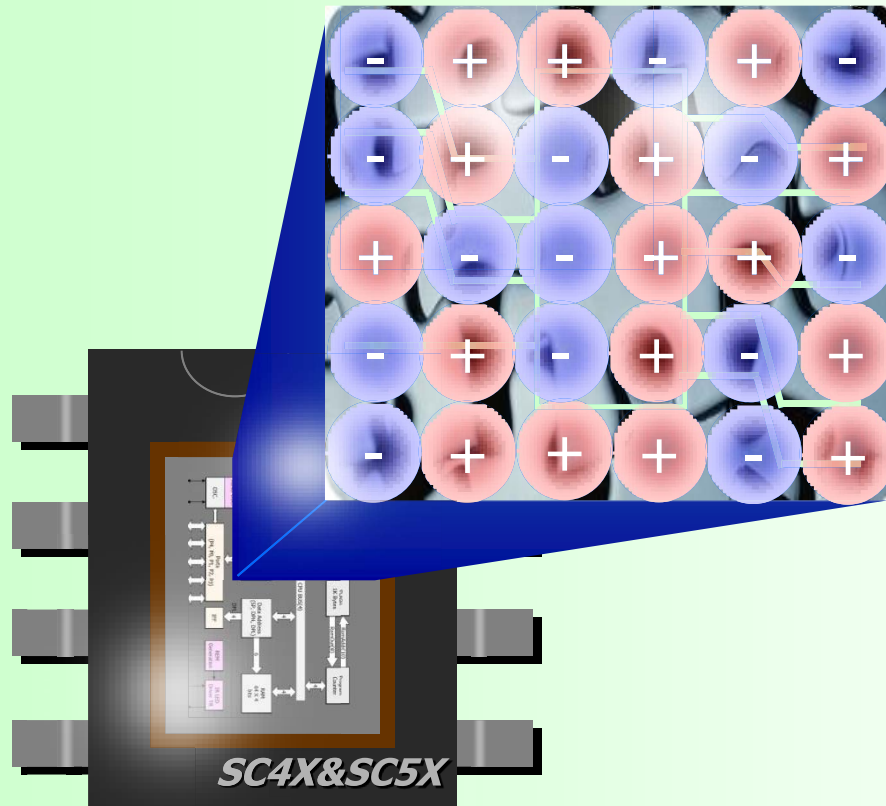

- ✓ The security algorithm is not hard-wired.
- ✓ It is really impossible to find it by de-cap.

## 8. Strong Point of CORERIVER SC50 (2/2)

*Confidential*

### ◆ Upgrade function in the field.

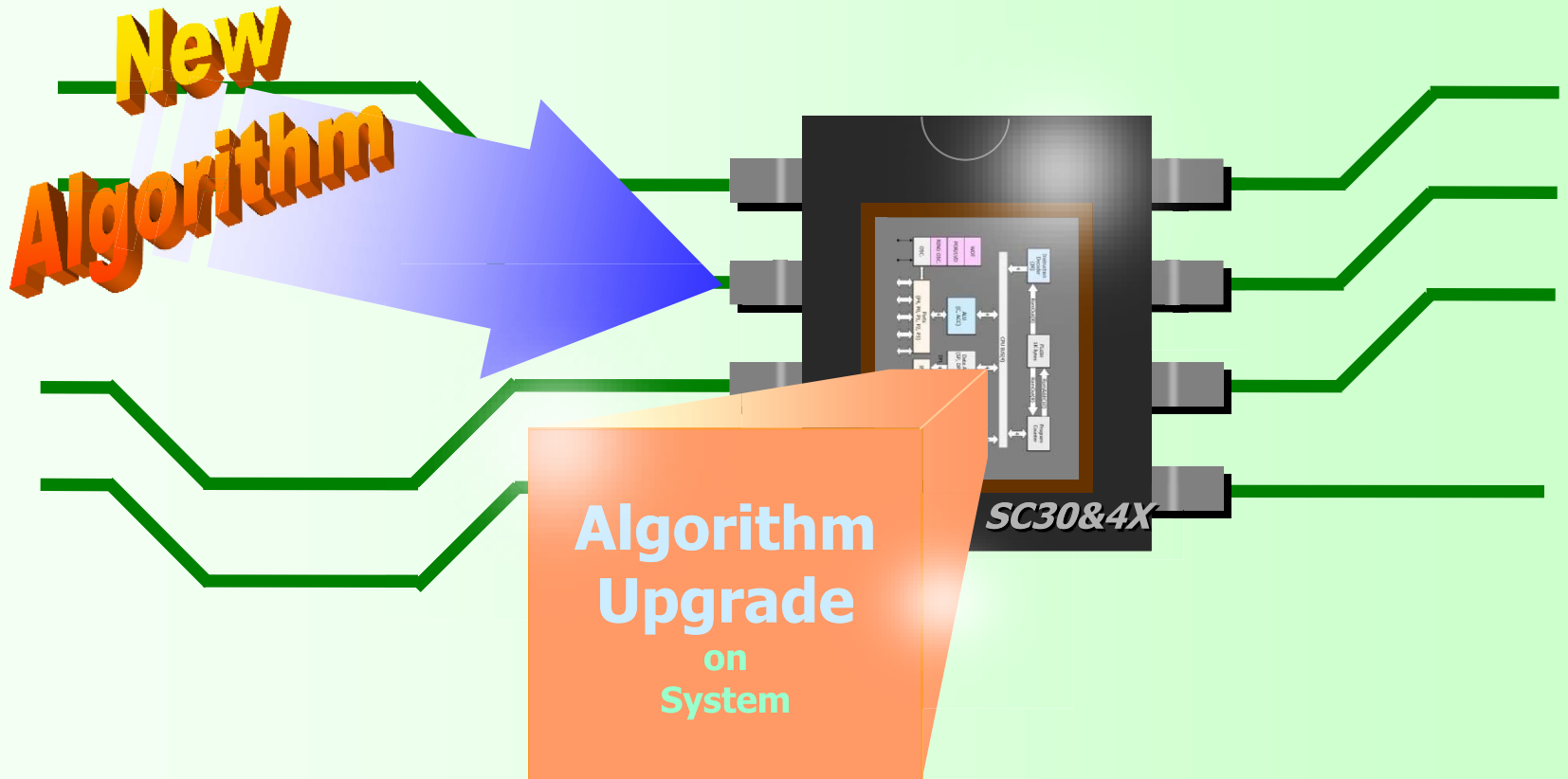

- ✓ CORERIVER SC50 can upgrade the security algorithm on a used system.
- ✓ To prevent the security algorithm from being cracked, you can replace it by a new one.

# 9. Security Flow

*Confidential*

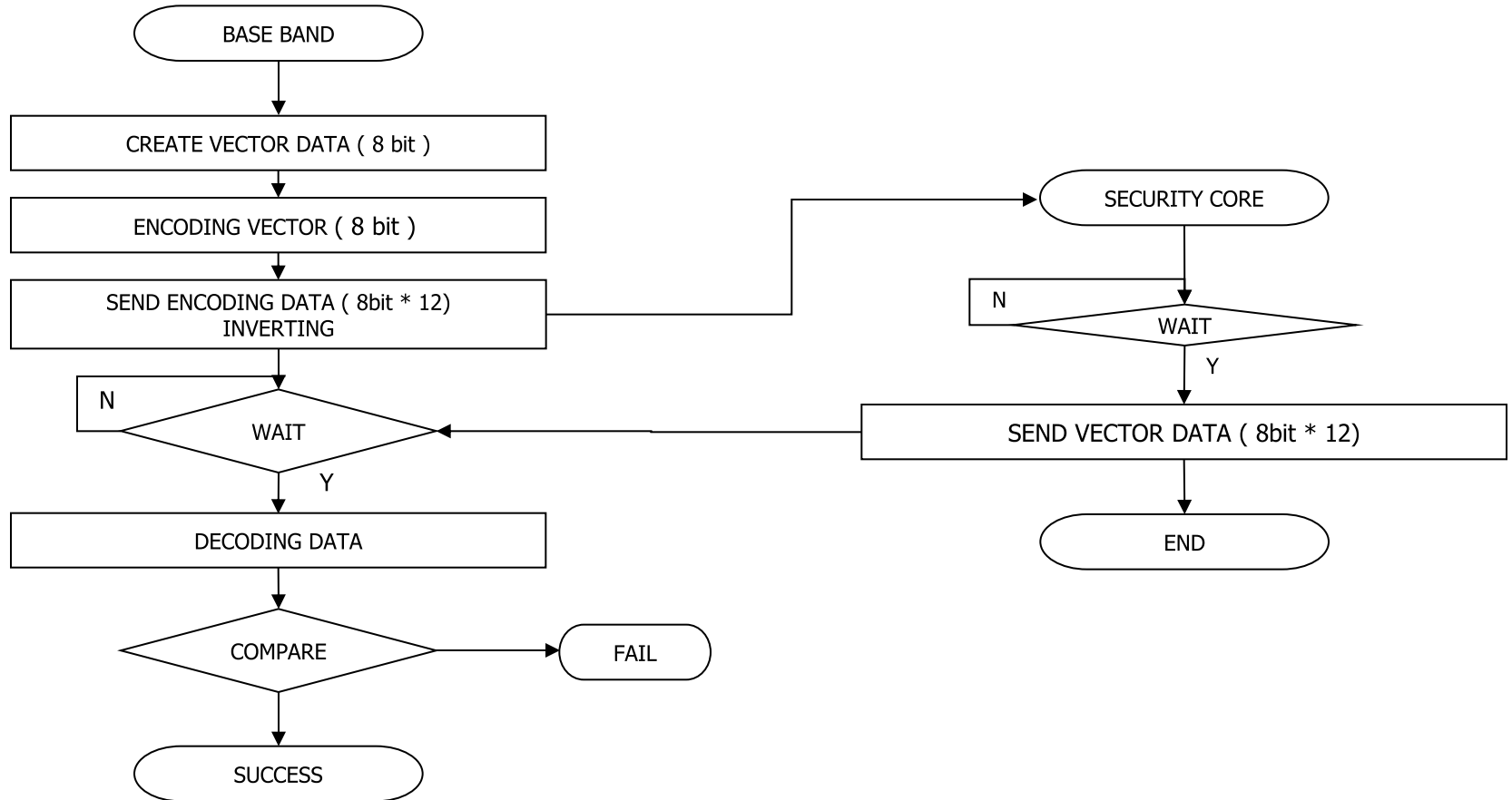

# 10.1 I2C Interface : 10-bit Addressing (Slave)

*Confidential*

## ◆ Single Byte Read with Memory Address

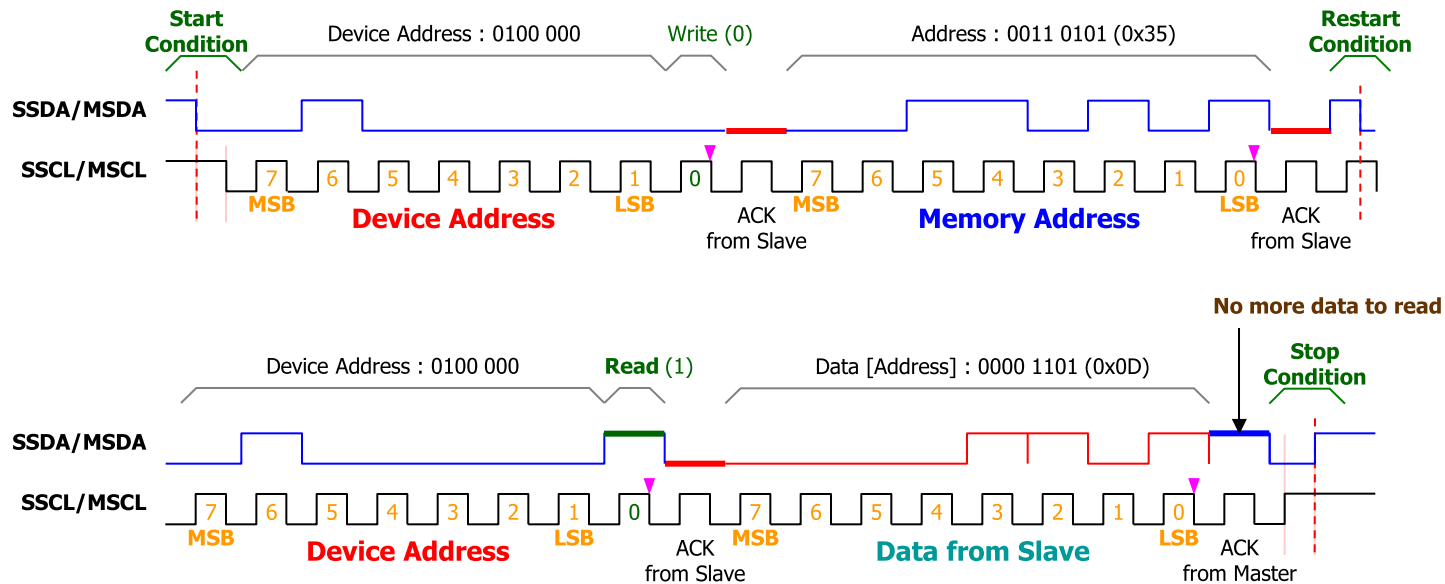

# 10.2 I2C Interface : 10-bit Addressing (Slave)

*Confidential*

## ◆ Single Byte Write with Memory Address

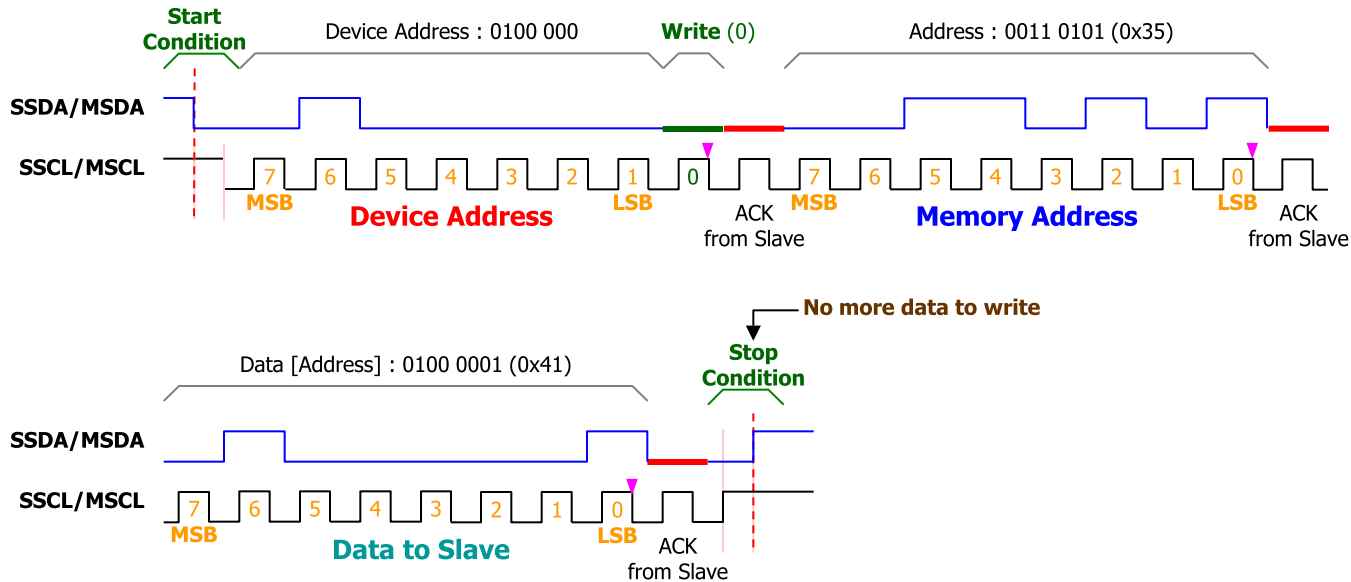

# 10.3 I2C Interface : 10-bit Addressing (Slave)

Confidential

## ◆ Multi (N) Bytes Read with Memory Address

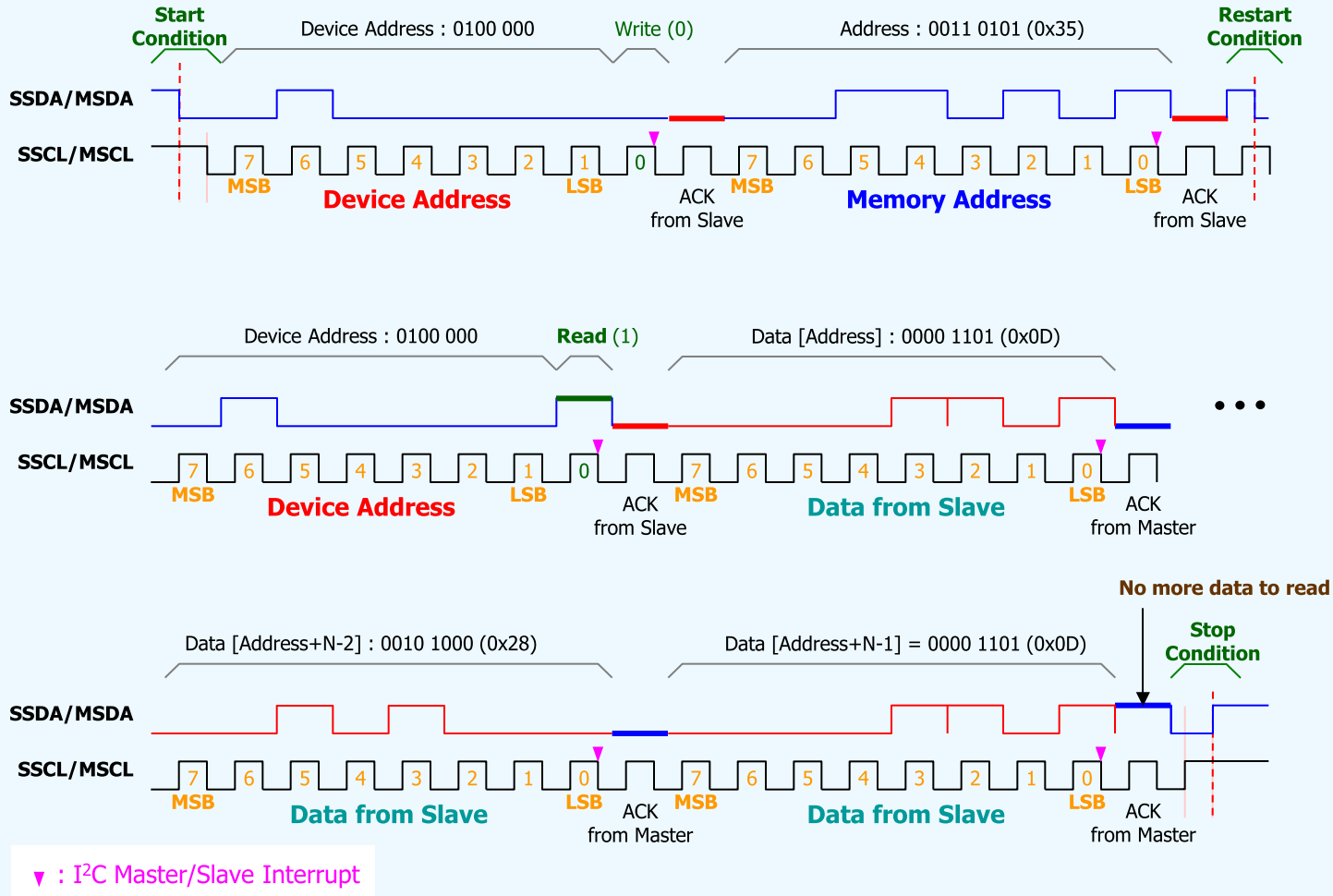



# 10.4 I2C Interface : 10-bit Addressing (Slave)

Confidential

## ◆ Multi (N) Bytes Write with Memory Address

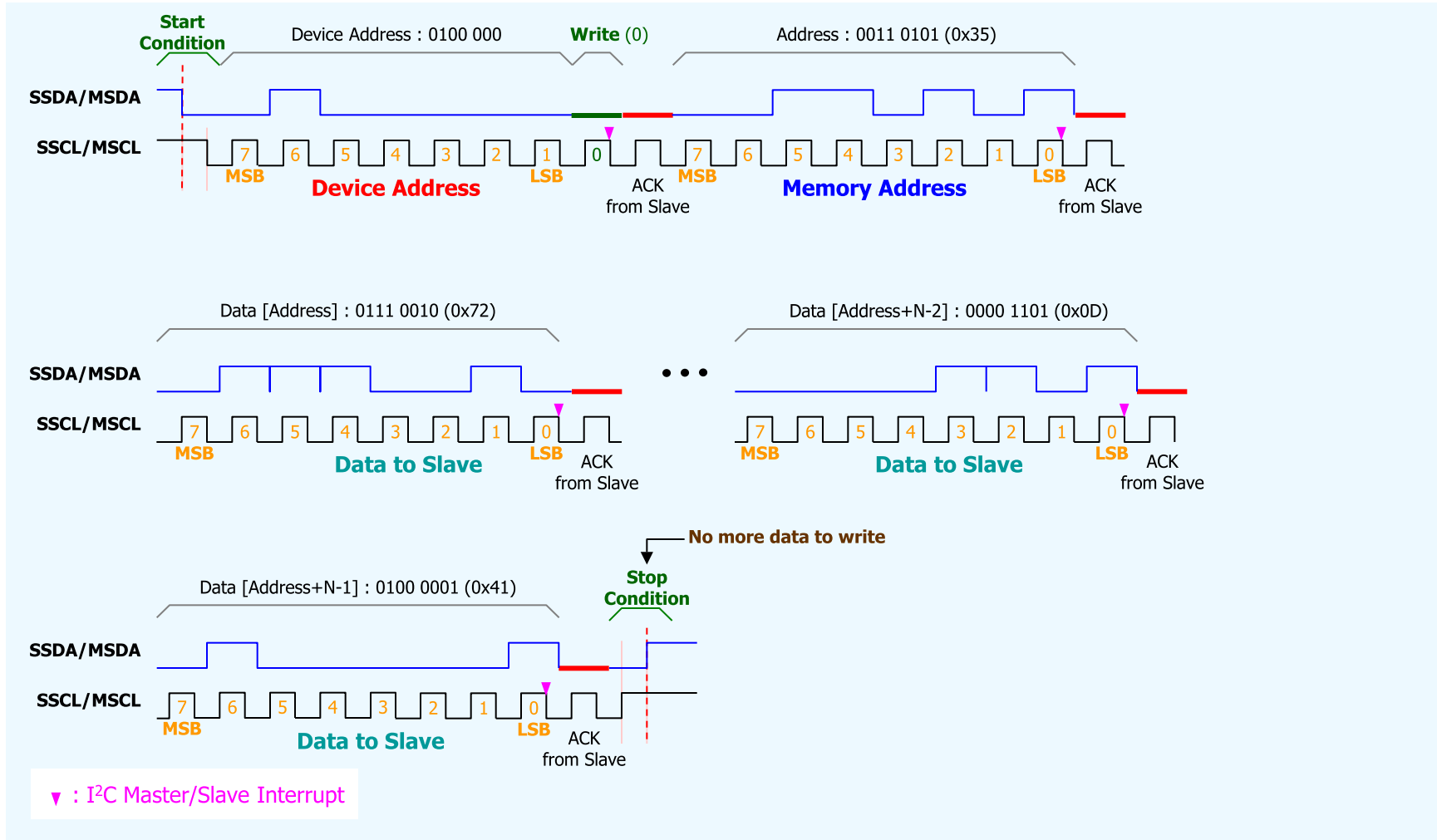

## 10.5 I2C Interface : Processing Time (5/5)

*Confidential*

### ◆ I2C Interface - Delay

No	Process	Time
1	Chip Address – Data Delay	20us
2	Data – Stop Delay	20us
3	Write – Read Delay (Algorithm processing time)	100ms

## 11. I2C Speed

*Confidential*

Device	I2C Min Speed	I2C Max Speed
SecurityCore 5.0	3KHz	400KHz

\* Recommended I2C Speed : 30KHz ~ 100KHz.

## 12. How to support Library

*Confidential*

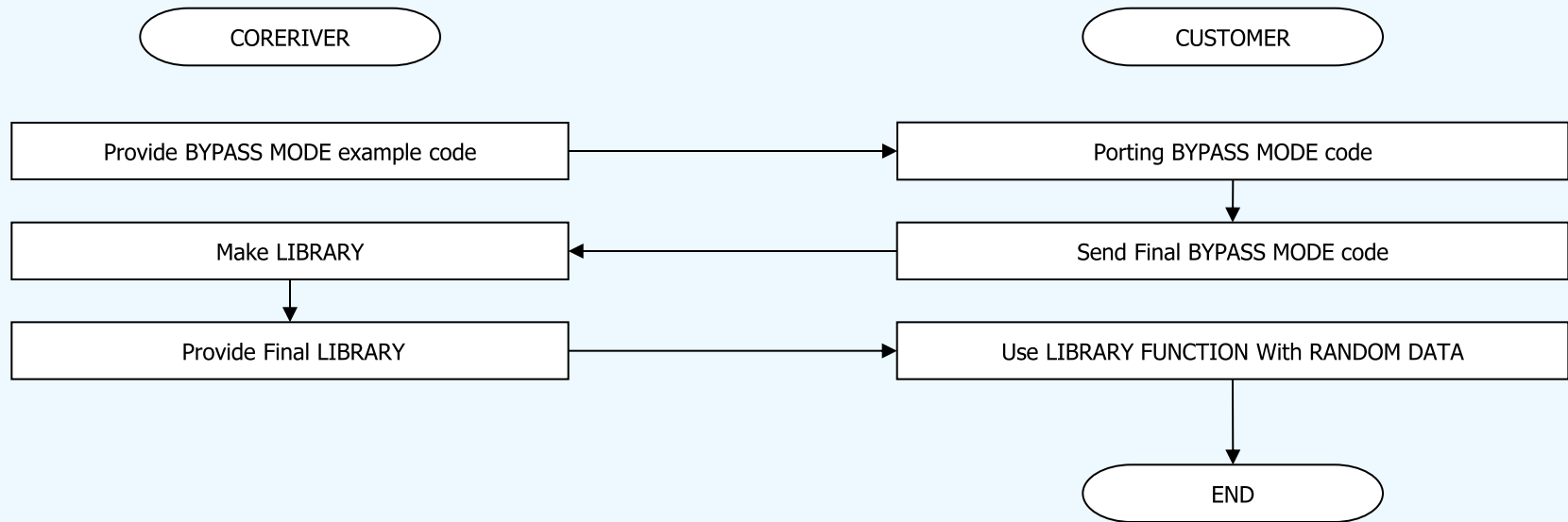

**NOTE : If CORERIVER don't have customer's development environment, we can borrow customer's IDE or visit customer's company to make library.**

## 13. Absolute Maximum Ratings

*Confidential*

Items	Conditions	Ranges
Voltage on any pin relative to Ground	-	-0.5V to ( $V_{DD}+0.5V$ )
Voltage in $V_{DD}$ relative to Ground	-	-0.5V to 6.5V
Output Voltage	-	-0.5V to ( $V_{DD}+0.5V$ )
Output Current High	One I/O pin active	-25mA
	All I/O pin active	-100mA
Output Current Low	One I/O pin active	+30mA
	All I/O pin active	+150mA
Operating Temperature	-	-40 °C to 85 °C
Storage Temperature	-	-65 °C to +150 °C
Soldering Temperature	-	Peak 260 °C for 10 seconds

# 14 DC Characteristics

*Confidential*

\* TA = -40 °C ~ +85 °C, V<sub>DD</sub> = 2.7V ~ 5.5V unless otherwise specified.

Parameter	Symbol	Pin	Conditions	Value			Unit
				Min.	Typ.	Max.	
Input Low Voltage	V <sub>IL1</sub>	RESETB ,P0, P1, P2	V <sub>DD</sub> = 2.2V~5.5V	-0.5	-	0.2V <sub>DD</sub> -0.1	V
	V <sub>IL2</sub>	XTAL1, XTAL2		-0.5	-	0.3V <sub>DD</sub>	
Input high Voltage	V <sub>IH1</sub>	RESETB, P0, P1 ,P2	V <sub>DD</sub> = 2.2V~5.5V	0.2V <sub>DD</sub> +1.0	-	V <sub>DD</sub> +0.5	V
	V <sub>IH2</sub>	XTAL1, XTAL2		0.7V <sub>DD</sub>	-	V <sub>DD</sub> +0.5	
Output Low Voltage	V <sub>OL</sub>	All Pins	I <sub>OL</sub> = 17mA @V <sub>DD</sub> =5V I <sub>OL</sub> = 7mA @V <sub>DD</sub> =3V I <sub>OL</sub> = 4mA @V <sub>DD</sub> =2.4V	-	-	0.3V <sub>DD</sub>	V
	V <sub>OL2</sub>	P0[3:0] when high drive is enabled	I <sub>OL</sub> = 50mA @V <sub>DD</sub> =5V I <sub>OL</sub> = 20mA @V <sub>DD</sub> =3V I <sub>OL</sub> = 12mA @V <sub>DD</sub> =2.4V	-	-	0.3V <sub>DD</sub>	V
Output High Voltage	V <sub>OH</sub>	All Pins	I <sub>OH</sub> = -18mA @V <sub>DD</sub> =5V I <sub>OH</sub> = -6mA @V <sub>DD</sub> =3V I <sub>OH</sub> = -3mA @V <sub>DD</sub> =2.4V	0.7V <sub>DD</sub>	-	-	V
	V <sub>OH2</sub>	P0[3:0] when high drive is enabled	I <sub>OH</sub> = -26mA @V <sub>DD</sub> =5V I <sub>OH</sub> = -8mA @V <sub>DD</sub> =3V I <sub>OH</sub> = -4mA @V <sub>DD</sub> =2.4V	0.7V <sub>DD</sub>	-	-	V
	V <sub>OHP</sub>	ALL Pins (Pull-up Resistor Only)	I <sub>OHP</sub> = -49uA @V <sub>DD</sub> =5V I <sub>OHP</sub> = -28uA @V <sub>DD</sub> =3V I <sub>OHP</sub> = -22uA @V <sub>DD</sub> =2.4V	0.7V <sub>DD</sub>	-	-	V
Input Leakage Current	I <sub>IL</sub>	All Pins Except of XTAL1, XTAL2	V <sub>IN</sub> = V <sub>IH</sub> or V <sub>IL</sub>	-	-	±1	μA
Pin Capacitance	C <sub>IO</sub>	All Pins	V <sub>DD</sub> = 5V	-	10	-	pF

# 14 DC Characteristics

*Confidential*

\* TA = -40 °C ~ +85 °C, V<sub>DD</sub> = 2.7V ~ 5.5V unless otherwise specified.

Parameter	Symbol	Pin	Conditions	Value			Unit
				Min.	Typ.	Max.	
Input Low Voltage	V <sub>IL1</sub>	RESETB ,P0, P1, P2	V <sub>DD</sub> = 2.2V~5.5V	-0.5	-	0.2V <sub>DD</sub> -0.1	V
	V <sub>IL2</sub>	XTAL1, XTAL2		-0.5	-	0.3V <sub>DD</sub>	
Input high Voltage	V <sub>IH1</sub>	RESETB, P0, P1 ,P2	V <sub>DD</sub> = 2.2V~5.5V	0.2V <sub>DD</sub> +1.0	-	V <sub>DD</sub> +0.5	V
	V <sub>IH2</sub>	XTAL1, XTAL2		0.7V <sub>DD</sub>	-	V <sub>DD</sub> +0.5	
Output Low Voltage	V <sub>OL</sub>	All Pins	I <sub>OL</sub> = 17mA @V <sub>DD</sub> =5V I <sub>OL</sub> = 7mA @V <sub>DD</sub> =3V I <sub>OL</sub> = 4mA @V <sub>DD</sub> =2.4V	-	-	0.3V <sub>DD</sub>	V
	V <sub>OL2</sub>	P0[3:0] when high drive is enabled	I <sub>OL</sub> = 50mA @V <sub>DD</sub> =5V I <sub>OL</sub> = 20mA @V <sub>DD</sub> =3V I <sub>OL</sub> = 12mA @V <sub>DD</sub> =2.4V	-	-	0.3V <sub>DD</sub>	V
Output High Voltage	V <sub>OH</sub>	All Pins	I <sub>OH</sub> = -18mA @V <sub>DD</sub> =5V I <sub>OH</sub> = -6mA @V <sub>DD</sub> =3V I <sub>OH</sub> = -3mA @V <sub>DD</sub> =2.4V	0.7V <sub>DD</sub>	-	-	V
	V <sub>OH2</sub>	P0[3:0] when high drive is enabled	I <sub>OH</sub> = -26mA @V <sub>DD</sub> =5V I <sub>OH</sub> = -8mA @V <sub>DD</sub> =3V I <sub>OH</sub> = -4mA @V <sub>DD</sub> =2.4V	0.7V <sub>DD</sub>	-	-	V
	V <sub>OHP</sub>	ALL Pins (Pull-up Resistor Only)	I <sub>OHP</sub> = -49uA @V <sub>DD</sub> =5V I <sub>OHP</sub> = -28uA @V <sub>DD</sub> =3V I <sub>OHP</sub> = -22uA @V <sub>DD</sub> =2.4V	0.7V <sub>DD</sub>	-	-	V
Input Leakage Current	I <sub>IL</sub>	All Pins Except of XTAL1, XTAL2	V <sub>IN</sub> = V <sub>IH</sub> or V <sub>IL</sub>	-	-	±1	μA
Pin Capacitance	C <sub>IO</sub>	All Pins	V <sub>DD</sub> = 5V	-	10	-	pF

# 15. AC Characteristics

*Confidential*

\* TA = -40 °C ~ +85 °C unless otherwise specified.

Parameter	Symbol	Pin	Conditions	Value			Unit
				Min.	Typ.	Max.	
Operating Frequency	F <sub>SYS</sub>	Internal Oscillator XTAL1, XTAL2	V <sub>DD</sub> = 5V ± 10%	-	-	24	MHz
			V <sub>DD</sub> = 3V ± 10%	-	-	12	
RESETB Input Width	t <sub>RST</sub>	RESETB	V <sub>DD</sub> = 5V ± 10%	20	-	-	us
			V <sub>DD</sub> = 3V ± 10%	20	-	-	
External Interrupt Input Width	t <sub>INT</sub>	External Interrupt	V <sub>DD</sub> = 5V ± 10%	4	-	-	F <sub>SYS</sub>
			V <sub>DD</sub> = 3V ± 10%	4	-	-	

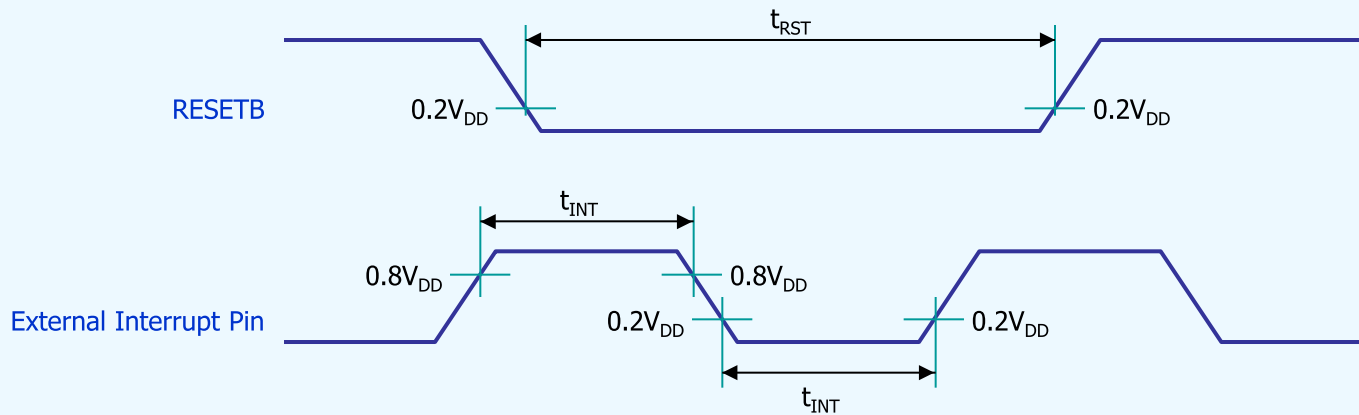



# 16. Package Dimensions : 8-SOIC

*Confidential*

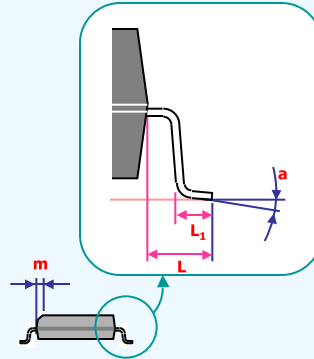
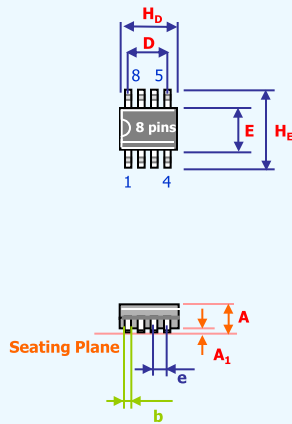

[8-SOIC]

Symbol	Dimension in Inches			Dimension in mm		
	Min.	Nom.	Max.	Min.	Nom.	Max.
A	0.093	0.099	0.104	2.35	2.45	2.65
$A_1$	0.004	0.008	0.012	0.10	0.20	0.30
b	0.014	0.016	0.019	0.35	0.42	0.49
D	-	0.150	-	-	3.81	-
E	0.150	0.153	0.157	3.80	3.90	4.00
$H_p$	0.189	0.193	0.197	4.80	4.90	5.00
$H_r$	0.234	0.239	0.244	5.95	6.07	6.20
L	0.038	0.043	0.048	0.97	1.08	1.2
$L_1$	0.022	0.027	0.032	0.58	0.70	0.82
a	0°	-	8°	0°	-	8°
e	0.050 BSC			1.27 BSC		
m	0.010	0.015	0.020	0.25	0.37	0.50

**Notes:**

1. Dimension D & E include mold mismatch and are determined at the mold parting line.
2. General appearance spec. should be based on final visual inspection spec.

## Appendix : Update History

- ◆ V1.0
  - ✓ spec draft
- ◆ V1.1
  - ✓ What's copy protection Image.
- ◆ V1.2
  - ✓ I2C Interface.
- ◆ V1.3
  - ✓ Package Dimensions.
- ◆ V1.4
  - ✓ SecurityCore3.0 Addition.
- ◆ V1.5
  - ✓ SecurityCore3.0 Strong Point Addition.
- ◆ V1.6
  - ✓ SecurityCore3.0 power slop Addition
- ◆ V1.7
  - ✓ SecurityCore4.0 Addition
- ◆ V1.8
  - ✓ SecurityCore4.1 Addition
- ◆ V1.9
  - ✓ SecurityCore412 Addition
- ◆ V2.0
  - ✓ SecurityCore412 strong point Addition
- ◆ V2.1 ~ V2.6
  - ✓ SecurityCore412 Addition
- ◆ V2.7
  - ✓ SecurityCore3.0 remove.
  - ✓ Algorithm & etc modify.
- ◆ V2.8
  - ✓ Power Characteristics remove.
  - ✓ I2C Speed change (10KHz -> 100KHz)
- ◆ V2.9
  - ✓ SS of SecurityCore5.0 only
  - ✓ Update I2C single byte Read/Write
  - ✓ Title changing : SecurityCore5.0