

TC308M

Capacitive Touch Sensor Controller

CORERIVER Semiconductor reserves the right to make corrections, modifications, enhancements, improvements, and other changes to its products and services at any time.

- ◆ *To discontinue any product or service, CORERIVER should inform customers of that before 3 months through its homepage.*
- ◆ *Customers should obtain the latest relevant information before placing orders and should verify that such information is current and complete.*
- ◆ *The CORERIVER Semiconductor products listed in this document are intended for usage in general electronics applications. These CORERIVER Semiconductor products are neither intended nor warranted for usage in equipment that requires extraordinarily high quality and/or reliability or a malfunction or failure of which may cause loss of human life or bodily injury.*

Copyright CORERIVER Semiconductor Co., Ltd. 2017

All Rights Reserved

1 TC308M Overview

1.1 General Description

TC308M is a high-performance Controller for capacitive touch keys. Its engine is an 8-bit 80C51 compatible Processor.

TC308M has two timer/counters, maximum 8-channel of touch sensors, maximum 12 programmable I/O pins, 4-channel 8-bit PWMs, 1 Watchdog timer, POR (Power-On Reset), I²C and LVD (Low Voltage Detector) as peripherals. In addition, it contains an internal ring oscillator, which can generate the 25 MHz system clock signal.

TC308M has its own architecture for fast sensing. With the hardware filter, it provides noise immunity and excellent sensitivity. The firmware algorithm supports smart sensitivity and compensates for changes in the sensitivity due to environmental factors such as temperature and humidity.

To effectively manage power, **TC308M** enables low power consumption by using scan interval and clock control methods after last touch.

TC308M operates over the extended -40°C to +85°C temperature range, and is available in the 16-pin QFN package.

1.2 Features

- ◆ Capacitive touch key controller
 - Supports up to 4 single-type touch keys
 - Supports scroll bar-type touch keys
 - Supports wheel-type touch keys
- ◆ Key Response Time
 - The latency of < 20ms for touch, subject to configuration
 - Programmable sensing rate for power saving.
- ◆ CPU
 - 8-bit Turbo 80C52 Architecture
 - 4 Cycles / 1 Machine Cycle

- Instruction Level Compatible with Intel 80C52
- ◆ Memory
 - 16KB Flash
 - 768B Internal Aux. RAM
 - 256B Internal RAM
- ◆ Power Supply
 - Operating Voltage: +2.2V to +5.5V
- ◆ Operating Frequency: Max. 25MHz
- ◆ 12 Programmable I/O Pins
- ◆ 4-channel 8-bit PWMs
- ◆ Communication interfaces
 - 1-channel I2C Communication (Slave)
- ◆ Internal Ring OSC with Calibration function
- ◆ Supporting ISP/IAP
- ◆ 8 Internal Interrupt Sources and 3 External Interrupt Sources
- ◆ 3 Reset Sources
- ◆ Power Down Wake-up Sources
 - Reset Sources + 3 External Interrupt (Both Levels)
 - Sleep Timer Interrupt
- ◆ 4 operating modes: Active, IDLE, Sleep, Deep Sleep
- ◆ E.S.D. Protection up to
 - 8,000V
- ◆ Latch-up Protection Up to $\pm 200\text{mA}$
- ◆ Package
 - 16-pin QFN (0.55T)
 - 20-pin TSSOP

1.3 Applications

- ◆ TV, Monitor, Home Theater
- ◆ Refrigerator, Washer, Air conditioner
- ◆ Mobile Phones
- ◆ Battery power applications

1.4 Product Family Guide

Product	FLASH, [Byte]	RAM [Byte]	Volt [V]	COM I/O	PWM (bit X ch)	I/O Pins	Touch Channel, Res.	Package	Others
TC308M-QF16IP	16K	768 + 256	2.2 ~ 5.5	I2C 1 Ch	8 X 4	12	8, 65,536	16-QFN	IAP ISP LVR POR RING
TC308M-TS20IP			VDDIO (2.2 ~ 5.5) VDDHOST (1.8 ~ 5.5)			12	8, 65,536	20-TSSOP	

2 Block Diagram

Figure shows the block diagram of **TC308M**. Programs reside in the internal program memory (Embedded Flash Memory). Data are read from or written to data memory (SRAM) or special function registers (SFRs).

The internal registers of **TC308M** are configured as part of the on-chip RAM: therefore each register has an address. This is reasonable for **TC308M**, since it has so many registers.

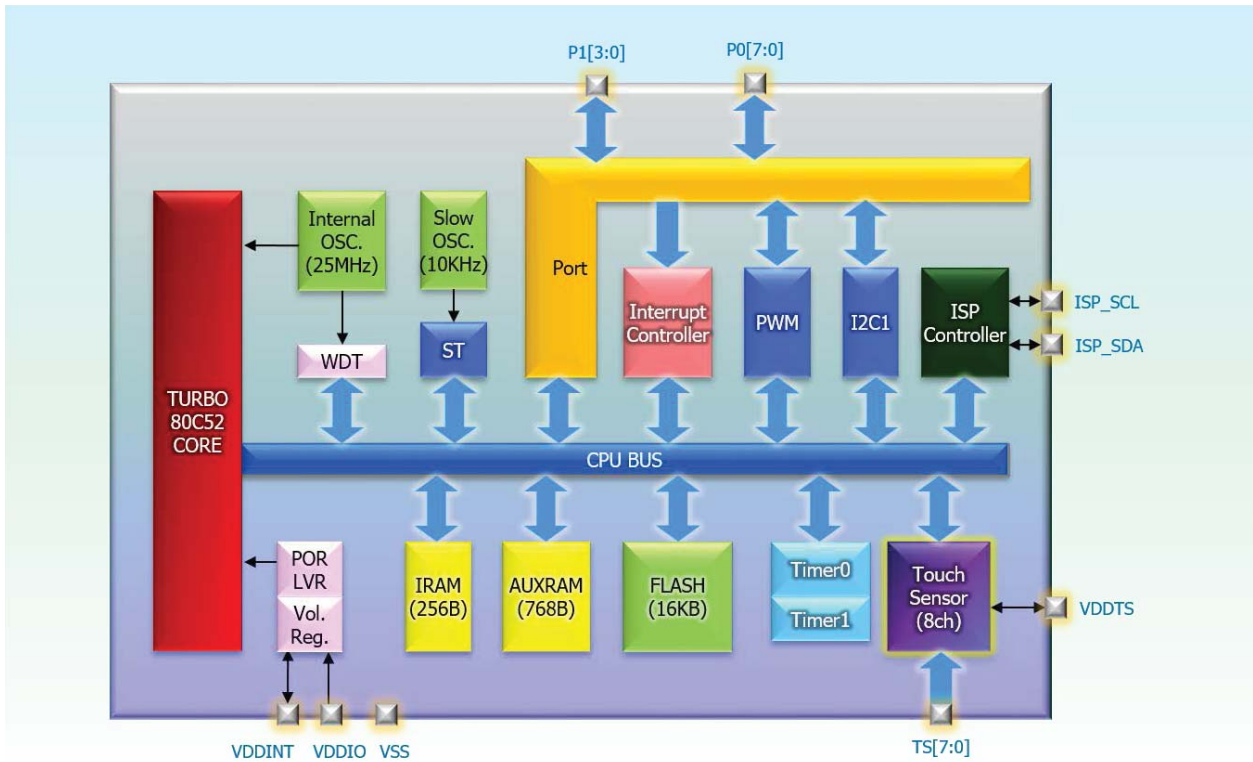

3 Pin Configuration

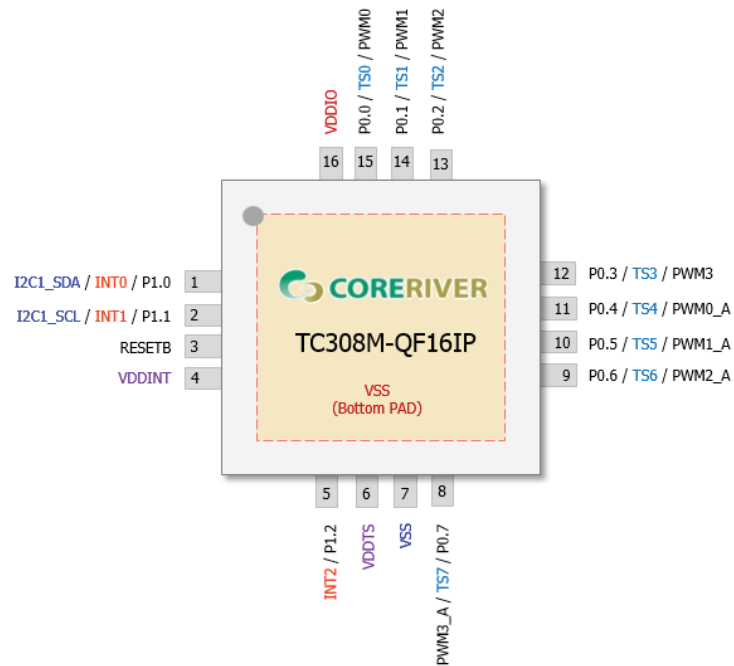

TC308M-QF16IP Package Diagram

Pin No. 16-QFN	Name	Type	Description	Share Pins
1	P1.0	I/O	General I/O Port 1.0	I2C1_SDA / INT0
2	P1.1	I/O	General I/O Port 1.1	I2C1_SCL / INT1
3	RESETB	I/O	Reset Pin	INT3 / GPIO
4	VDDINT	O	Digital Power Filter	
5	P1.2	I/O	General I/O Port 1.2	INT2
6	VDDTS	O	Touch Sensor Power Filter	
7	VSS	GND	Ground	
8	P0.7	I/O	General I/O Port 0.7	Touch Sensing Channel 7 PWM3_A
9	P0.6	I/O	General I/O Port 0.6	Touch Sensing Channel 6 PWM2_A
10	P0.5	I/O	General I/O Port 0.5	Touch Sensing Channel 5 PWM1_A
11	P0.4	I/O	General I/O Port 0.4	Touch Sensing Channel 4 PWM0_A
12	P0.3	I/O	General I/O Port 0.3	Touch Sensing Channel 3 PWM3
13	P0.2	I/O	General I/O Port 0.2	Touch Sensing Channel 2 PWM2
14	P0.1	I/O	General I/O Port 0.1	Touch Sensing Channel 1 PWM1
15	P0.0	I/O	General I/O Port 0.0	Touch Sensing Channel 0 PWM0
16	VDDIO	PWR	Power Supply	

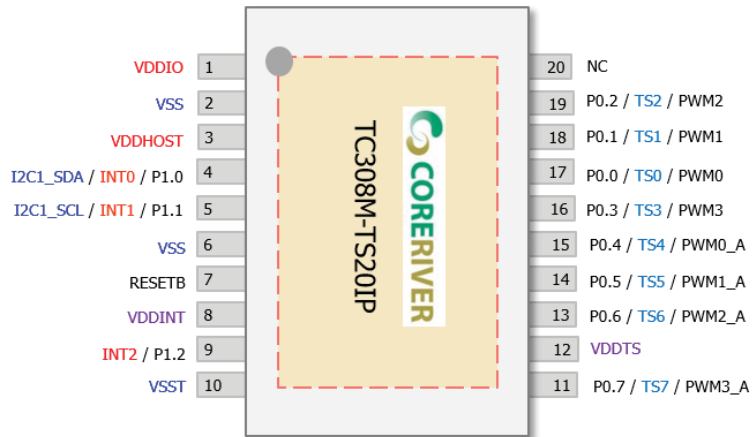

TC308M-TS20IP Package Diagram

Pin No. 20-TSSOP	Name	Type	Description	Share Pins
1	VDDIO	PWR	Power Supply	
2	VSS	GND	Ground	
3	VDDHOST	PWR	Power Supply	
4	P1.0	I/O	General I/O Port 1.0	I2C1_SDA / INT0
5	P1.1	I/O	General I/O Port 1.1	I2C1_SCL / INT1
6	VSS	GND	Ground	
7	RESETB	I/O	Reset Pin	INT3 / GPIO
8	VDDINT	O	Digital Power Filter	
9	P1.2	I/O	General I/O Port 1.2	INT2
10	VSST	GND	Ground	
11	P0.7	I/O	General I/O Port 0.7	Touch Sensing Channel 7 PWM3_A
12	VDDTS	O	Touch Sensor Power Filter	
13	P0.6	I/O	General I/O Port 0.6	Touch Sensing Channel 6 PWM2_A
14	P0.5	I/O	General I/O Port 0.5	Touch Sensing Channel 5 PWM1_A
15	P0.4	I/O	General I/O Port 0.4	Touch Sensing Channel 4 PWM0_A
16	P0.3	I/O	General I/O Port 0.3	Touch Sensing Channel 3 PWM3

17	P0.0	I/O	General I/O Port 0.0	Touch Sensing Channel 0 PWM0
18	P0.1	I/O	General I/O Port 0.1	Touch Sensing Channel 1 PWM1
19	P0.2	I/O	General I/O Port 0.2	Touch Sensing Channel 2 PWM2
20	NC			

4 Absolute Maximum Ratings

. Absolute Maximum Ratings (TA = 25 °C)

Item	Conditions	Range
DC Voltage in V _{DDIO} relative to Ground	-	-0.5 V to +6V
DC Input Voltage	-	-0.5V to (V _{DDIO} +0.5V)
DC Output Voltage	-	-0.5 V to (V _{DDIO} +0.5V)
DC Output Current High	One I/O pin active	-25mA
	All I/O pin active	-100mA
DC Output Current Low	One I/O pin active	+30mA
	All I/O pin active	+150mA
Storage Temperature	-	-65 °C to +150 °C
Soldering Temperature	-	260 °C for 10 seconds

. Recommended Operating Conditions

Item	Conditions	Range
Operating Voltage	-	+2.2V to +5.5V
Operating Temperature	-	-40°C to + 85°C

5 DC Characteristics

* $T_A = -40^{\circ}\text{C} \sim +85^{\circ}\text{C}$, $V_{DD} = 2.2\text{V} \sim 5.5\text{V}$ unless otherwise specified

Parameter	Symbol	Pin	Conditions	Value			Unit
				Min.	Typ.	Max.	
Input Low Voltage	V_{IL}	P0, P1	$V_{DDIO} = +2.2\text{V to } +5.5\text{V}$	-0.5	-	$0.2V_{DDIO} + 0.1$	V
Input high Voltage	V_{IH}	P0, P1	$V_{DDIO} = +2.2\text{V to } +5.5\text{V}$	$0.2V_{DDIO} + 1.0$	-	$V_{DDIO} + 0.5$	V
Output Low Voltage	V_{OL}	P0, P1	$V_{DDIO} = +5.0\text{V}$ ($I_{OL} = 8\text{mA}$) $V_{DDIO} = +3.3\text{V}$ ($I_{OL} = 4\text{mA}$)	-	-	$0.3V_{DDIO}$	V
		P0, P1 (High Drive)	$V_{DDIO} = +3.3\text{V}$ ($I_{OL} = 35\text{mA}$)	-	-	$0.3V_{DDIO}$	V
Output High Voltage	V_{OH}	P0, P1	$V_{DDIO} = +5.0\text{V}$ ($I_{OH} = -12\text{mA}$) $V_{DDIO} = +3.3\text{V}$ ($I_{OH} = -6\text{mA}$)	$0.7V_{DDIO}$	-	-	V
Pull-up Resistor	R_{Pu}	P0	$V_{DDIO} = +5.0\text{V}$ $V_{DDIO} = +3.3\text{V}$		37.5 45		$\text{k}\Omega$
Pull-up Resistor	R_{Pu1}	P1	$V_{DDIO} = +5.0\text{V}$ $V_{DDIO} = +3.3\text{V}$		37.5 45		$\text{k}\Omega$
Logical 1 to 0 Transition Current	I_{TL}	P0, P1	$V_{DDIO} = 5.0\text{V} \pm 10\%$ ($V_{IN} = +1.5\text{V}$)	-	548	-	μA
Input Leakage Current	I_{IL}	P0, P1	$V_{IN} = V_{IH}$ or V_{IL}	-	-	± 1	μA
Pin Capacitance	C_{IO}	All	$V_{DDIO} = +5.0\text{V}$	-	10	-	pF
Active Current	I_{DD}	V_{SS}	$V_{DDIO} = +2.2\text{V}$, $T_A = 25^{\circ}\text{C}$, $F_{SYS} = 12.5\text{MHz}$, Touch Sampling rate = 100Hz(4 Channels), no I/O sourcing current	-	1.3	2.1	mA
Sleep Current	I_{SB}	V_{SS}	$V_{DDIO} = +2.2\text{V}$, $T_A = 25^{\circ}\text{C}$, no I/O sourcing current	1	2	5	μA

6 AC Characteristics

* $T_A = -40\text{ }^\circ\text{C} \sim +85\text{ }^\circ\text{C}$, $V_{DDIO} = 2.2\text{V} \sim 5.5\text{V}$ unless otherwise specified

Parameter	Symbol	Pin	Conditions	Value			Unit
				Min	Typ	Max	
RESETB Input Width	t_{RST}	RESETB	$V_{DDIO} = 3\text{V} \pm 10\%$	24	-	-	F _{sys}
External Interrupt Input Width	t_{INT}	External Interrupt	$V_{DDIO} = 3\text{V} \pm 10\%$	4	-	-	F _{sys}

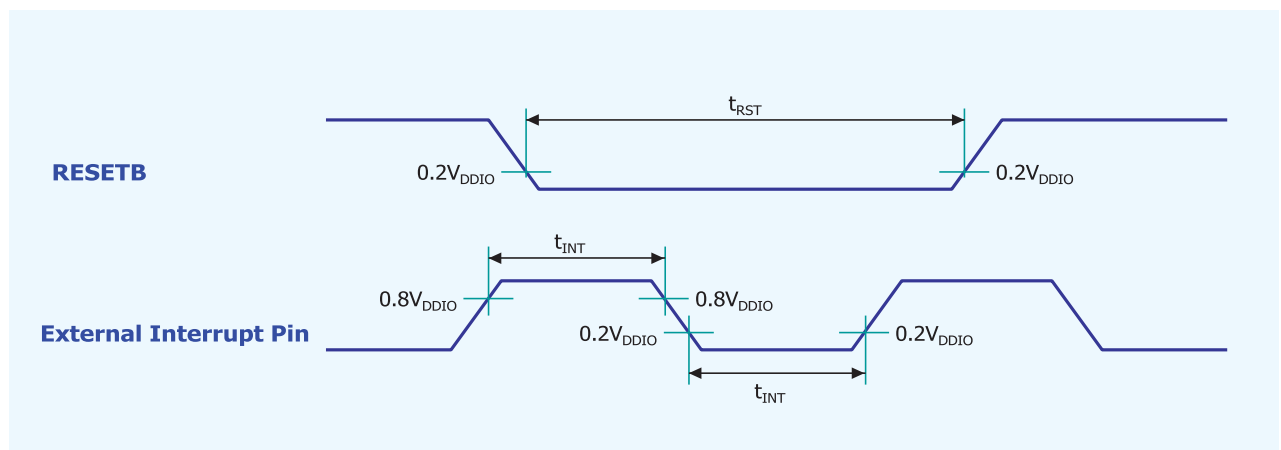

7 I2C Timing Characteristics

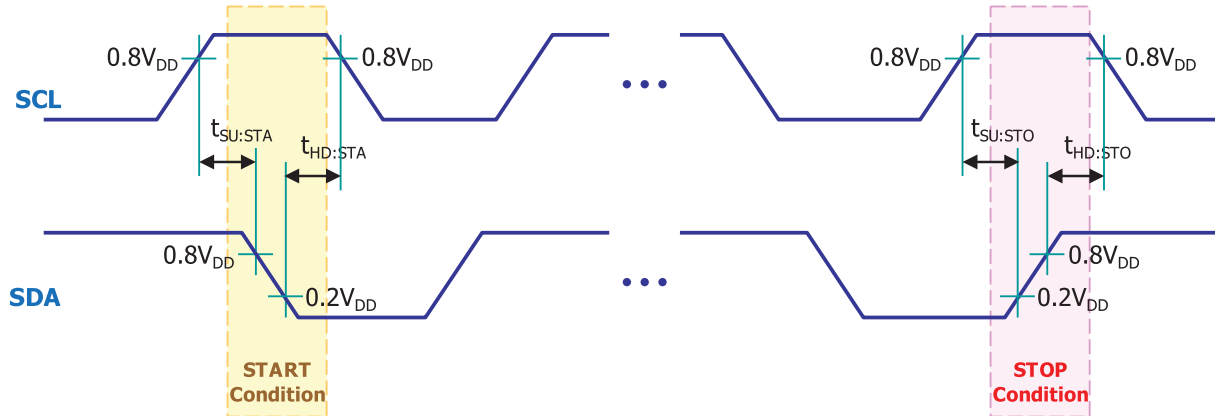

Symbol	Characteristics		Min. [ns]	Max. [ns]	Conditions
$t_{SU:STA}$	START Condition Setup Time	100kHz Mode	4,700	-	Only relevant for repeated START condition
		400kHz Mode	600	-	
$t_{HD:STA}$	START Condition Hold Time	100kHz Mode	4,700	-	After this period, the first clock pulse is generated
		400kHz Mode	600	-	
$t_{SU:STO}$	STOP Condition Setup Time	100kHz Mode	4,700	-	
		400kHz Mode	600	-	
$t_{HD:STO}$	STOP Condition Hold Time	100kHz Mode	4,700	-	
		400kHz Mode	600	-	

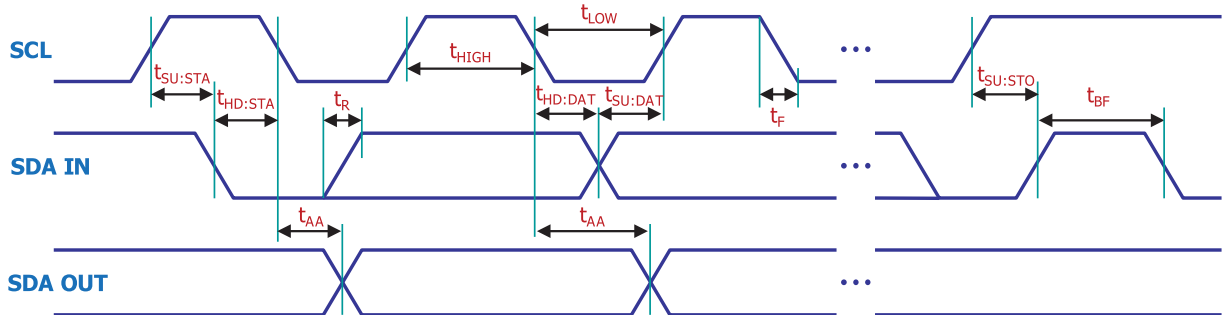

Symbol	Characteristics		Min. [ns]	Max. [ns]	Conditions
t_{HIGH}	Clock High Time	100kHz Mode	4,000	-	Minimum Frequency : 1MHz
		400kHz Mode	600	-	Minimum Frequency : 5MHz
t_{LOW}	Clock Low Time	100kHz Mode	4,700	-	Minimum Frequency : 1MHz
		400kHz Mode	1,300	-	Minimum Frequency : 5MHz
$t_{SU:DAT}$	Data Input Setup Time	100kHz Mode	250	-	
		400kHz Mode	100	-	
$t_{HD:DAT}$	Data Input Hold Time	100kHz Mode	0	-	
		400kHz Mode	0	900	
t_{AA}	Data Valid from Clock	100kHz Mode	-	3,500	
		400kHz Mode	-	-	
t_{BF}	BUS Free Time	100kHz Mode	4,700	-	
		400kHz Mode	1,300	-	
t_R	SDA & SCL Rising Time	100kHz Mode	-	1,000	The Range of Cb is from 10pF to 400pF
		400kHz Mode	$2.0 + 0.1C_b$	300	
t_F	SDA & SCL Falling Time	100kHz Mode	-	300	The Range of Cb is from 10pF to 400pF
		400kHz Mode	$2.0 + 0.1C_b$	300	

8.2 TSSOP 20 Pin

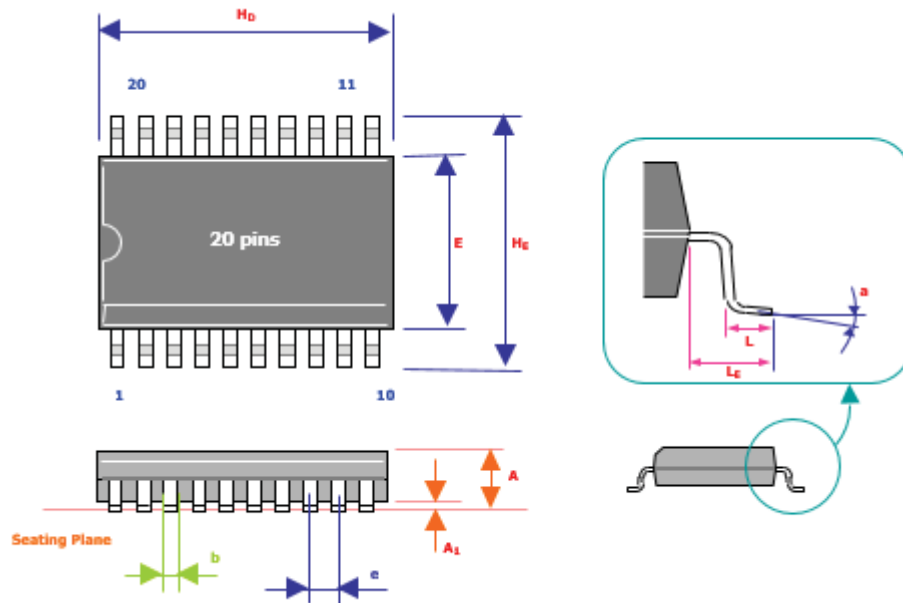

Symbol	Dimensions [mm]		
	Min.	Nom.	Max.
A	-	-	1.20
A ₁	0.05	-	0.15
a	0 °C	-	8 °C
b	0.19		0.30
E	4.30	4.40	4.50
e	0.65 BSC		
H _D	7.70	7.80	7.90
H _E	6.20	6.40	6.60
L	0.45	0.60	0.75
L _E	1.00 REF		

Notes:

1. All Dimension are in mm. Angles in Degrees.
2. Dimension b applies to Plated Terminal & is measured.
3. BSC: Basic Dimension. Theoretically exact value shown without tolerances.
REF: Reference Dimension, Usually without tolerance, for information purpose only.

9 Revision History

Date	Revision	History
July.-2018	1.0	Release
Mar - 2021	1.1	Notation error corrected.
Sep.-2021	1.2	On page 14 QFN16 Package Dimension description error e2 is corrected to e1.

TC308M – QF16IP

Body Size : 3mm X 3mm

»VDDIO [Operating Voltage] : +2.5V to +5.5V
 »VDDIIC [IIC Pull Up Voltage] : +1.8V to VDDIO

* C1, C2 : Mandatory
 Power Noise filter Cap
 C1 : 0.1uF
 C2 : 2.2uF

* R1 ~ R8 : Option
 ESD Countermeasure
 Value : 0 ~ 3K [ohm]

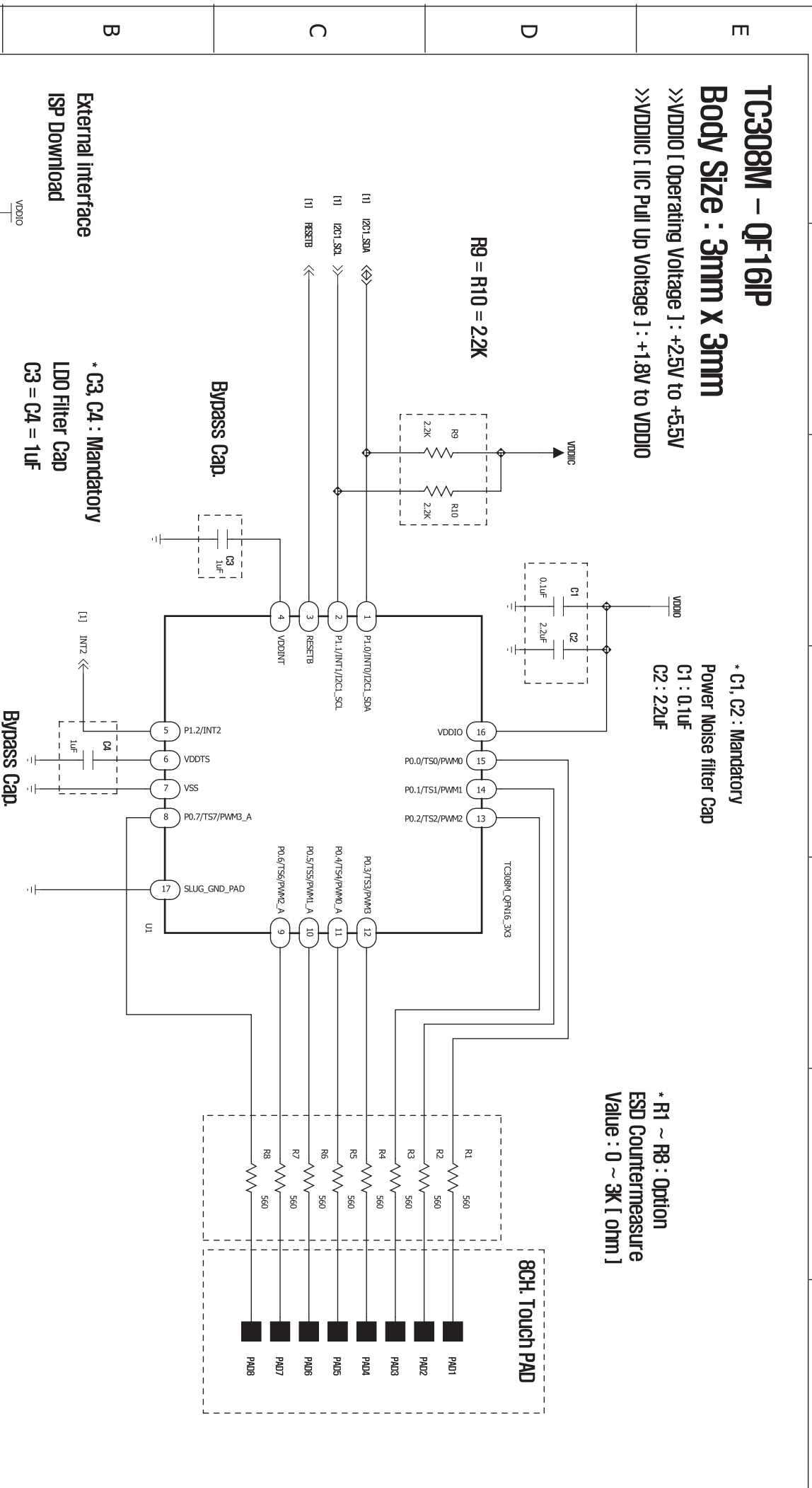

External interface
ISP Download

* C3, C4 : Mandatory
 LDO Filter Cap
 C3 = C4 = 1uF

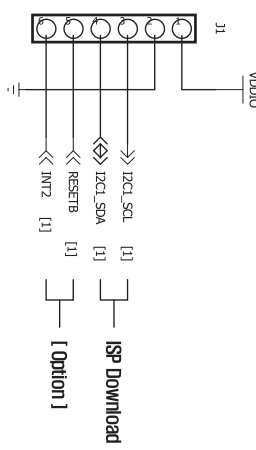

NO	REVISION NO.	NO.	REVISION NO.	C	B	A	NO	PART NO.	DESCRIPTION	MATERIAL	COLOR FINISH	NOTE
1												
2												

QUANTITY	SCALE	UNIT	DRAWN
	A3	mm	2017-03-13

SHEET	1 / 1	mm	TC308M_QF16IP
-------	-------	----	---------------

CORRIVER		AprilPark
----------	--	-----------

TC308M-TS20IP

>> VDDIO [Operating Voltage] : +2.5V to +5.5V
 >> VDDIIC [IIC Pull UP Voltage] : +1.8V to VDDIO

* C1, C2 : Mandatory
 Power Noise filter Cap
 C1 : 0.1uF
 C2 : 22uF

* R1 ~ R8 : Option
 ESD Countermeasure
 Value : 0 ~ 3K [ohm]

8 CHANNEL
 TOUCH PAD

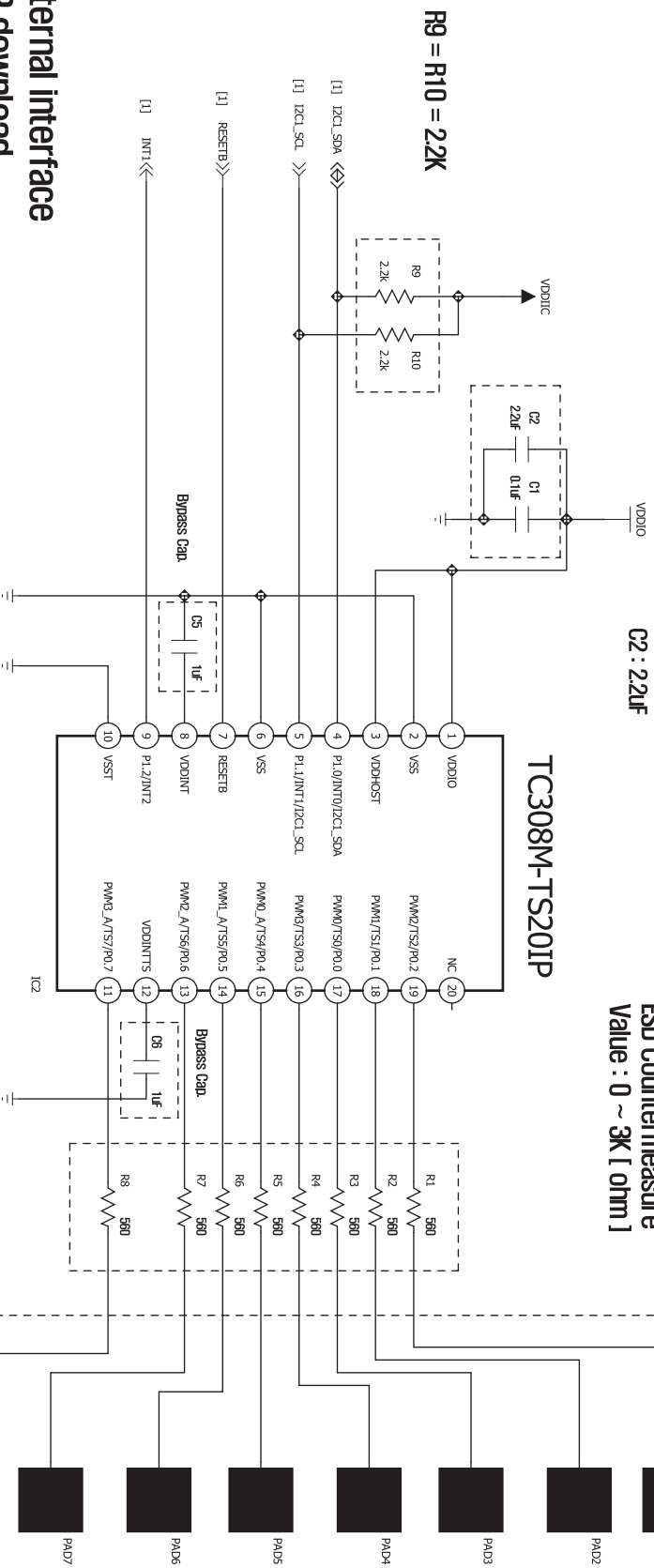

External interface ISP download

* C5, C6 : Mandatory
 LDO Filter Cap
 C5 = C6 = 1uF

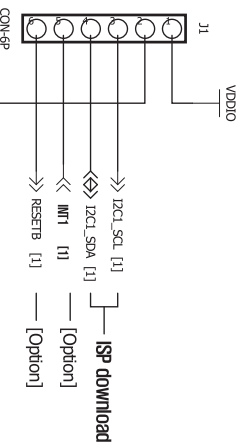

NO.	REVISION NO.	NO.	REVISION NO.	C	B	A	NO	PART NO.	DESCRIPTION	MATERIAL	COLOR FINISH	NOTE
1							SCALE	UNIT	DRAWN	DISCHEMATIC		
2							A3	mm	2017-03-14	TC308M_TSSOP_20		

SHEET 1 / 1

2017-03-14

TC308M_TSSOP_20