

TC350K

Capacitive Touch Sensor Controller

CORERIVER Semiconductor reserves the right to make corrections, modifications, enhancements, improvements, and other changes to its products and services at any time.

- ◆ *To discontinue any product or service, CORERIVER should inform customers of that before 3 months through its homepage.*
- ◆ *Customers should obtain the latest relevant information before placing orders and should verify that such information is current and complete.*
- ◆ *The CORERIVER Semiconductor products listed in this document are intended for usage in general electronics applications. These CORERIVER Semiconductor products are neither intended nor warranted for usage in equipment that requires extraordinarily high quality and/or reliability or a malfunction or failure of which may cause loss of human life or bodily injury.*

Copyright CORERIVER Semiconductor Co., Ltd. 2013

All Rights Reserved

1 TC350K Overview

1.1 General Description

TC350K is a high-performance Controller for capacitive touch keys. Its engine is an 8-bit 80C51 compatible Processor.

TC350K has two timer/counters, maximum 4-channel of touch sensors, maximum 11 programmable I/O pins, 4-channel 8-bit PWMs, 1 Watchdog timer, POR (Power-On Reset), I²C and LVD (Low Voltage Detector) as peripherals. In addition, it contains an internal ring oscillator, which can generate the 25 MHz system clock signal.

TC350K has its own architecture for fast sensing. With the hardware filter, it provides noise immunity and excellent sensitivity. The firmware algorithm supports smart sensitivity and compensates for changes in the sensitivity due to environmental factors such as temperature and humidity.

To effectively manage power, **TC350K** enables low power consumption by using scan interval and clock control methods after last touch.

TC350K operates over the extended -25°C to +85°C temperature range, and is available in the 16-pin QFN package.

1.2 Features

- ◆ Capacitive touch key controller
 - Supports up to 4 single-type touch keys
 - Supports scroll bar-type touch keys
 - Supports wheel-type touch keys
- ◆ Key Response Time
 - The latency of < 20ms for touch, subject to configuration
 - Programmable sensing rate for power saving.
- ◆ CPU
 - 8-bit Turbo 80C52 Architecture
 - 4 Cycles / 1 Machine Cycle
 - Instruction Level Compatible with Intel 80C52

- ◆ Memory
 - 8KB Flash
 - 768B Internal Aux. RAM
 - 256B Internal RAM
- ◆ Power Supply
 - Operating Voltage : +1.75V to +3.60V
- ◆ Operating Frequency: Max. 25MHz
- ◆ 11 Programmable I/O Pins
- ◆ 4-channel 8-bit PWMs
- ◆ Communication interfaces
 - 1-channel I2C Communication (Slave)
- ◆ Internal Ring OSC with Calibration function
- ◆ Supporting ISP/IAP
- ◆ 7 Internal Interrupt Sources and 3 External Interrupt Sources
- ◆ 3 Reset Sources
- ◆ Power Down Wake-up Sources
 - Reset Sources + 3 External Interrupt (Both Levels)
 - Watchdog Timer Interrupt
- ◆ Power Consumption
 - Active Current : Max. 1mA @+3.3V, 2MHz
 - Sleep Current : Typ. 15uA @+3.3V (ST on)
 - Deep Sleep Current: Typ. 3uA @+3.3V
- ◆ E.S.D. Protection up to
 - 8,000V
- ◆ Latch-up Protection Up to $\pm 200\text{mA}$
- ◆ Package
 - 16-pin QFN (0.5T)

1.3 Applications

- ◆ Home appliance: TV, Monitor, Home Theater
- ◆ Mobile Phones
- ◆ Portable MP3, MP4
- ◆ Digital Cameras
- ◆ Battery power applications

1.4 Product Family Guide

Product	Res.	FLASH [Byte]	RAM [Byte]	Volt [V]	Freq [MHz]	T/C [16/8bit]	COM I/O	PWM [bit x Ch]	WDT	I/O Pins	Touch Channel	Package	Other s
TC350K- QF16IP	65,536	8K	768 + 256	1.75 ~ 3.60	25	2	1 I2C	8 X 4	1	11	4	16-QFN (e-PAD) 3 x 3 mm 0.55T	IAP ISP LVR POR RING

2 Block Diagram

Figure shows the block diagram of **TC350K**. Programs reside in the internal program memory (Embedded Flash Memory). Data are read from or written to data memory (SRAM) or special function registers (SFRs).

The internal registers of **TC350K** are configured as part of the on-chip RAM: therefore each register has an address. This is reasonable for **TC350K**, since it has so many registers.

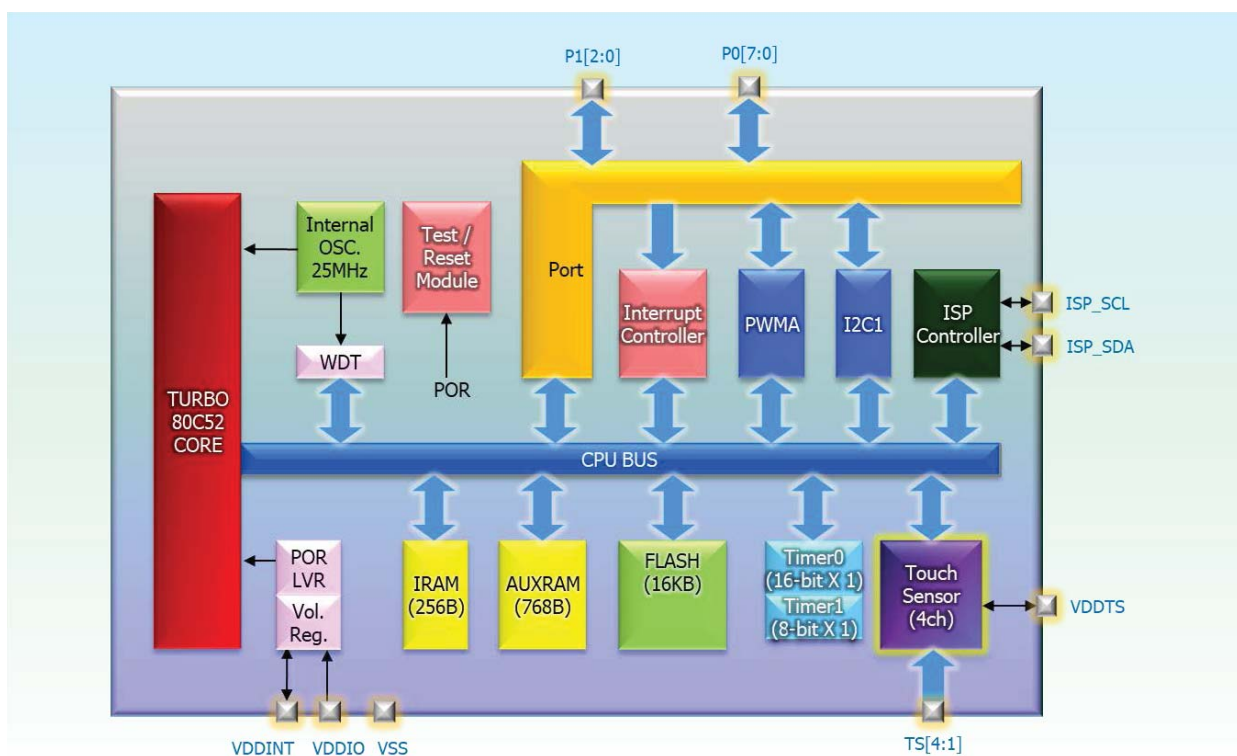

3 Pin Configuration

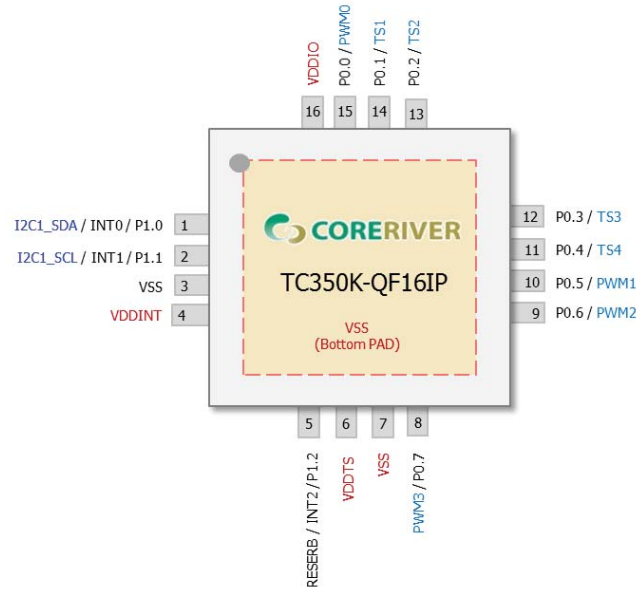

TC350K-QF16IP Package Diagram

Pin No.	Name	Type	Description	Share Pins
1	P1.0	I/O	General I/O Port 1.0	I2C1_SDA / INT0
2	P1.1	I/O	General I/O Port 1.1	I2C1_SCL / INT1
3	VSS	GND	Ground	
4	VDDINT	O	Digital Power Filter	
5	P1.2	I/O	General I/O Port 1.2	INT2 / RESETB
6	VDDINTS	O	Touch Sensor Power Filter	
7	VSS	GND	Ground	
8	P0.7	I/O	General I/O Port 0.7	PWM3
9	P0.6	I/O	General I/O Port 0.6	PWM2
10	P0.5	I/O	General I/O Port 0.5	PWM1
11	P0.4	I/O	General I/O Port 0.4	Touch Sensing Channel 4
12	P0.3	I/O	General I/O Port 0.3	Touch Sensing Channel 3
13	P0.2	I/O	General I/O Port 0.2	Touch Sensing Channel 2
14	P0.1	I/O	General I/O Port 0.1	Touch Sensing Channel 1
15	P0.0	I/O	General I/O Port 0.0	PWM0
16	VDDIO	PWR	Power Supply	

4 Absolute Maximum Ratings

.Absolute Maximum Ratings (TA = 25 °C)

Item	Conditions	Range
DC Voltage in V _{DDIO} relative to Ground	-	-0.5 V to +4.6V
DC Input Voltage	-	-0.5V to (V _{DDIO} +0.5V)
DC Output Voltage	-	-0.5 V to (V _{DDIO} +0.5V)
DC Output Current High	One I/O pin active	-25mA
	All I/O pin active	-100mA
DC Output Current Low	One I/O pin active	+30mA
	All I/O pin active	+150mA
Storage Temperature	-	-65 °C to +150 °C
Soldering Temperature	-	260 °C for 10 seconds

.Recommended Operating Conditions

Item	Conditions	Range
Operating Voltage	-	+1.75V to +3.60V
Operating Temperature	-	-25 °C to + 85 °C

5 DC Characteristics

* $T_A = -25^{\circ}\text{C} \sim +85^{\circ}\text{C}$, $V_{DD} = 1.75\text{V} \sim 3.60\text{V}$ unless otherwise specified

Parameter	Symbol	Pin	Conditions	Value			Unit
				Min.	Typ.	Max.	
Input Low Voltage	V_{IL}	P0, P1	$V_{DDIO} = +1.75\text{V to } +3.60\text{V}$	-0.5	-	$0.2V_{DDIO} + 0.1$	V
Input high Voltage	V_{IH}	P0, P1	$V_{DDIO} = +1.75\text{V to } +3.60\text{V}$	$0.2V_{DDIO} + 1.0$	-	$V_{DDIO} + 0.5$	V
Output Low Voltage	V_{OL}	P0, P1	$V_{DDIO} = +3.3\text{V} (I_{OL} = 4.20\text{mA})$ $V_{DDIO} = +1.8\text{V} (I_{OL} = 2.00\text{mA})$	-	-	$0.3V_{DDIO}$	V
		P0, P1 (High Drive)	$V_{DDIO} = +3.3\text{V} (I_{OL} = 34.14\text{mA})$ $V_{DDIO} = +1.8\text{V} (I_{OL} = 8.17\text{mA})$	-	-	$0.3V_{DDIO}$	V
Output High Voltage	V_{OH}	P0, P1	$V_{DDIO} = +3.3\text{V} (I_{OH} = -7.80\text{mA})$ $V_{DDIO} = +1.8\text{V} (I_{OH} = -2.22\text{mA})$	$0.7V_{DDIO}$	-	-	V
Pull-up Resistor	R_{Pu}	P0	$V_{DDIO} = +3.3\text{V}$		52		K Ω
	R_{Pu1}	P1	$V_{DDIO} = +3.3\text{V}$		5.6		K Ω
	R_{Pu2}		$V_{DDIO} = +2.2\text{V}$ (Internal 1.8V Pull-up)		2.2		K Ω
Logical 1 to 0 Transition Current	I_{TL}	P0, P1	$V_{DDIO} = 3.0\text{V} \pm 10\%$ ($V_{IN} = +2.0\text{V}$)	-	-	-650	μA
Input Leakage Current	I_{IL}	P0, P1	$V_{IN} = V_{IH}$ or V_{IL}	-	-	± 1	μA
Pin Capacitance	C_{IO}	All	$V_{DDIO} = +3.0\text{V}$	-	10	-	pF
Active Current	I_{DD}	V_{SS}	$V_{DDIO} = +1.8\text{V}$, $T_A = 25^{\circ}\text{C}$, $F_{SYS} = 12.5\text{MHz}$, Touch Sampling rate = 100Hz(4 Channels), no I/O sourcing current	-	1.31	2.1	mA
Sleep Current	I_{SB}	V_{SS}	$V_{DDIO} = +3.0\text{V}$, $T_A = 25^{\circ}\text{C}$, no I/O sourcing current	-	3	7	μA

6 AC Characteristics

* $T_A = -25\text{ }^{\circ}\text{C} \sim +85\text{ }^{\circ}\text{C}$, $V_{DD} = 1.75\text{V} \sim 3.60\text{V}$ unless otherwise specified

Parameter	Symbol	Pin	Conditions	Value			Unit
				Min	Typ	Max	
External Interrupt Input Width	t_{INT}	External Interrupt	$V_{DD} = 3\text{V} \pm 10\%$	4	-	-	F _{sys}

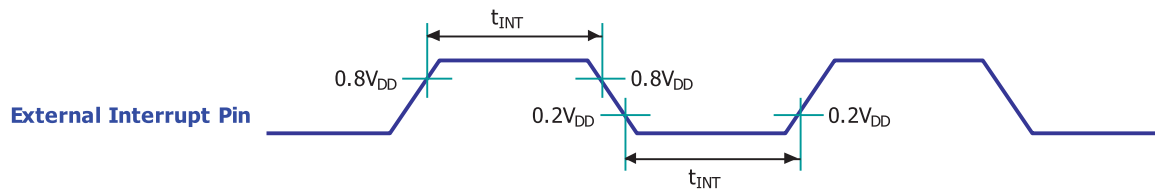

7 I2C Timing Characteristics

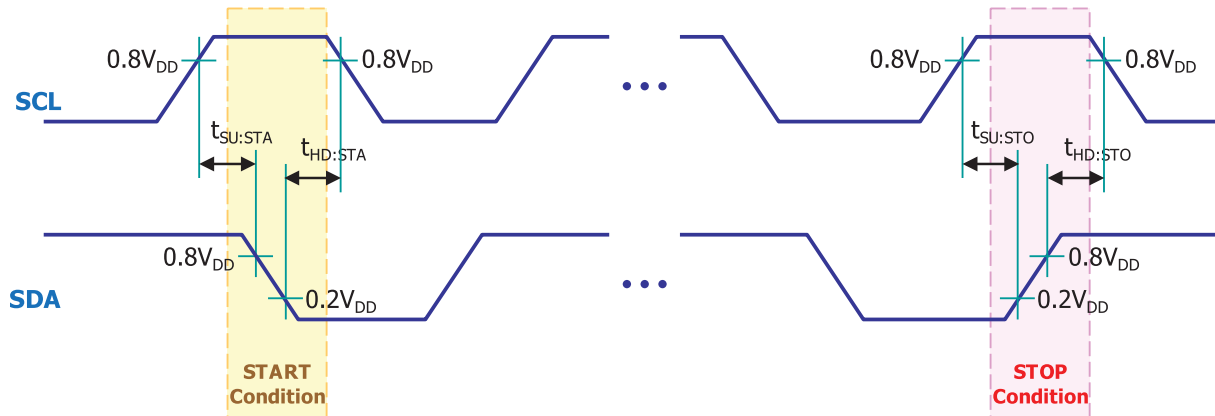

Symbol	Characteristics		Min. [ns]	Max. [ns]	Conditions
$t_{SU:STA}$	START Condition Setup Time	100kHz Mode	4,700	-	Only relevant for repeated START condition
		400kHz Mode	600	-	
$t_{HD:STA}$	START Condition Hold Time	100kHz Mode	4,700	-	After this period, the first clock pulse is generated
		400kHz Mode	600	-	
$t_{SU:STO}$	STOP Condition Setup Time	100kHz Mode	4,700	-	
		400kHz Mode	600	-	
$t_{HD:STO}$	STOP Condition Hold Time	100kHz Mode	4,700	-	
		400kHz Mode	600	-	

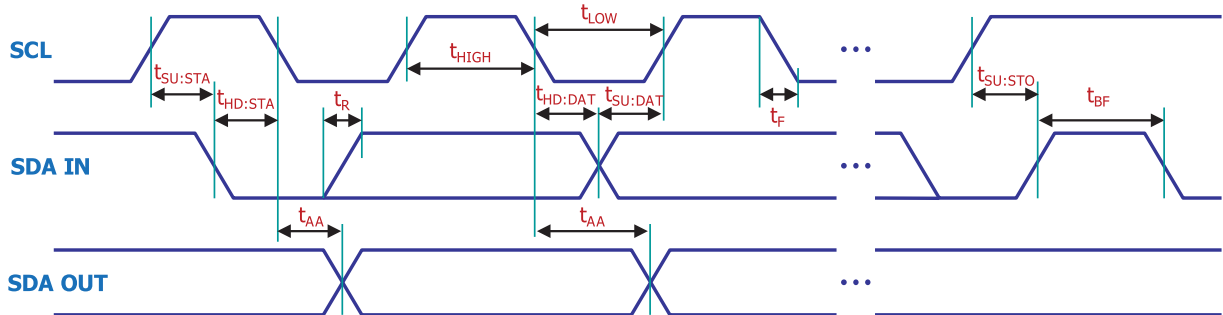

Symbol	Characteristics	Min. [ns]	Max. [ns]	Conditions	
t_{HIGH}	Clock High Time	100kHz Mode	4,000	-	Minimum Frequency : 1MHz
		400kHz Mode	600	-	Minimum Frequency : 5MHz
t_{LOW}	Clock Low Time	100kHz Mode	4,700	-	Minimum Frequency : 1MHz
		400kHz Mode	1,300	-	Minimum Frequency : 5MHz
$t_{SU:DAT}$	Data Input Setup Time	100kHz Mode	250	-	
		400kHz Mode	100	-	
$t_{HD:DAT}$	Data Input Hold Time	100kHz Mode	0	-	
		400kHz Mode	0	900	
t_{AA}	Data Valid from Clock	100kHz Mode	-	3,500	
		400kHz Mode	-	-	
t_{BF}	BUS Free Time	100kHz Mode	4,700	-	
		400kHz Mode	1,300	-	
t_R	SDA & SCL Rising Time	100kHz Mode	-	1,000	The Range of Cb is from 10pF to 400pF
		400kHz Mode	$2.0 + 0.1C_b$	300	
t_F	SDA & SCL Falling Time	100kHz Mode	-	300	The Range of Cb is from 10pF to 400pF
		400kHz Mode	$2.0 + 0.1C_b$	300	

8 16-pin QFN Package Dimension

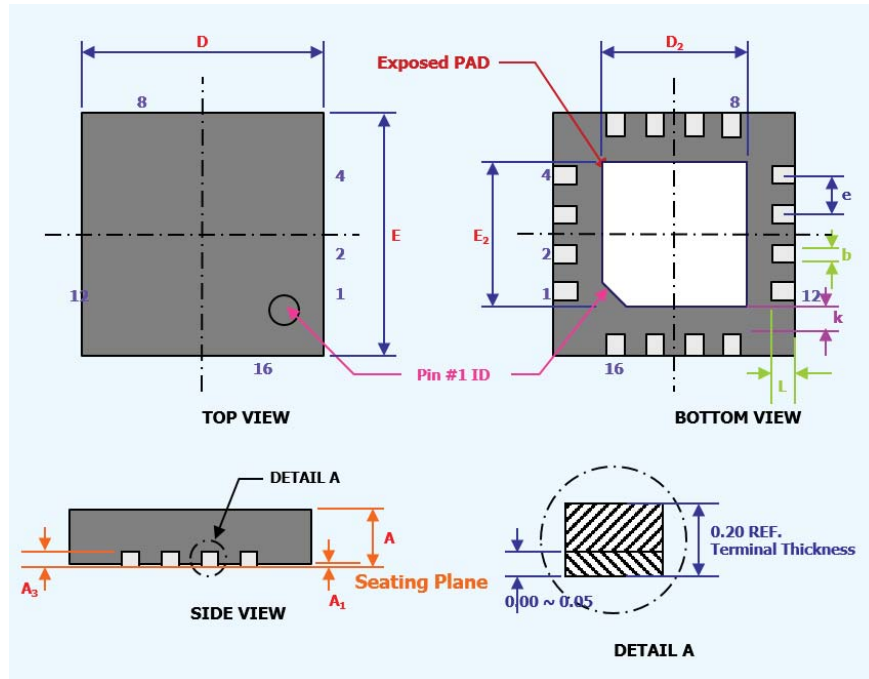

Symbol	Dimensions [mm]		
	Min.	Nom.	Max.
A	0.45	0.50	0.55
A ₁	0.00	-	0.05
A ₃	0.127 REF		
D	2.95	3.00	3.05
E	2.95	3.00	3.05
D ₂	1.70	1.80	1.90
E ₂	1.70	1.80	1.90
b	0.20	0.25	0.30
e	0.50 BSC		
L	0.30	0.35	0.40
k	0.25 REF		

Notes:

1. All Dimension are in mm. Angles in Degrees.
2. Dimension b applies to Plated Terminal & is measured.
3. BSC : Basic Dimension. Theoretically exact value shown without tolerances.
REF : Reference Dimension, Usually without tolerance, for information purpose only.

9 Revision History

Date	Revision	History
Nov.-2013	0.4	Preliminary release
Aug-2014	1.0	Updated "Operating Conditions (Voltage and Temperature)" and "PKG Dimension"
Nov-2014	1.1	Updated "DC Characteristics"
Jan-2017	1.2	Updated "1.8V Pull-up Resistor Characteristics"
Jan-2017	1.3	Added "Power Consumption"
Jan-2018	1.4	Modified "DC Characteristics"
Mar-2021	1.5	Notation error corrected.
May-2021	1.6	Updated "Operating Conditions (Voltage and Temperature)"

TC350K – QF16IP

Body Size : 3mm x 3mm

>> VDDIO [Operating Voltage] : +1.75V to +3.6V
 -> If you use the VDDIO Level to 1.8V or less, you'll need to connect the VDDIO and VDDINT.

* C3, C4 : Mandatory
 Power Noise filter Cap
 C3 : 0.1uF
 C4 : 22uF

* R1 ~ R4 : Option
 ESD Countermeasure
 Value : 0 ~ 3K [ohm]

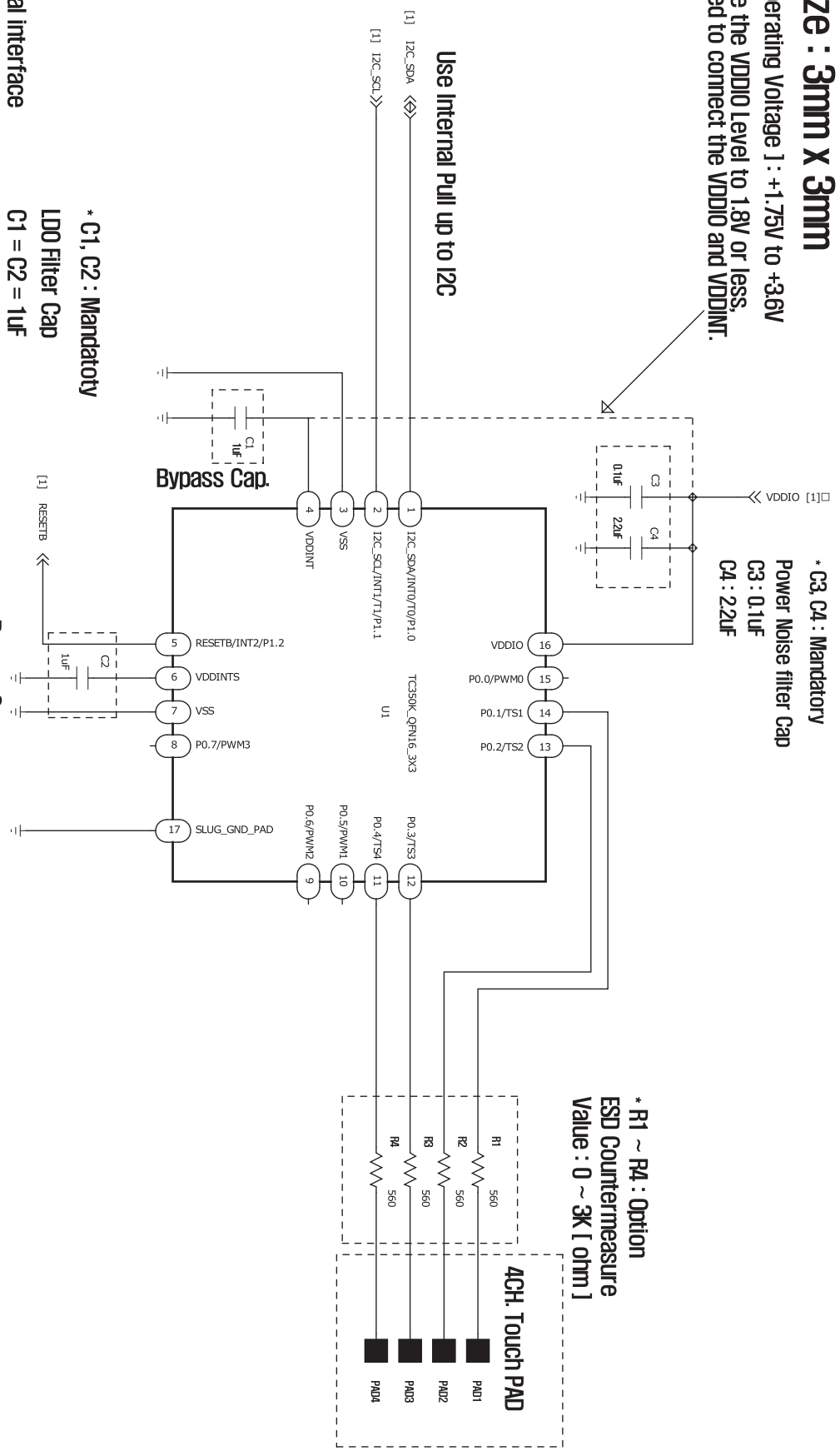

Use Internal Pull up to I2C

* C1, C2 : Mandatory
 LDO Filter Cap
 C1 = C2 = 1uF

External interface
 ISP Download

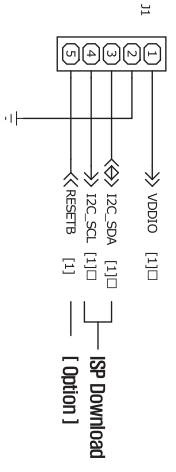

NO.	REVISION NO.	NO.	REVISION NO.	C	B	A	NO.	PART NO.	DESCRIPTION	MATERIAL	COLOR FINISH	NOTE
1				QUANTITY			NO.		DRAWN.			
2				SCALE			UNIT		2014-12-10			<undefined>
				A3			mm					
				SHEET			1 / 1		CORE RIVER			